

## Telco, the Original

A well established high tech Danish enterprise, formed in 1975, has become one of the most sought after high performance sensor manufacturers in the world. Telco's global success is the result of many years of listening to the experts – our customers.

All Telco sensors are manufactured in-house by skilled employees together with advanced automated production equipment. The strictest quality standards guarantee that both components and the finished product have undergone comprehensive quality inspections at each production stage achieving unmatched technical superiority.

Telco's wide range of sensors are typically used for counting, sorting, measuring, positioning and detecting within, but not limited to, the industries of steel, wood, packaging, material handling, bottling, agriculture, car wash, elevators and automatic doors. All Telco sensors are tolerant of hostile environments and are consequently the most versatile on the market with a 3 year world-wide warranty.

Telco is proudly represented by its own renowned subsidiaries and qualified representatives world-wide who provide 24 hour service with stock, just in time delivery, technical and on site application support.

Contact your local Telco representative today – seeing is believing!



### Contents

#### Remote Photoelectric Systems

■ Remote Sensors .....	page 3
■ PA 01 .....	page 7
■ PA 09 .....	page 9
■ PA 10 .....	page 11
■ PA 11 .....	page 13
■ MPA 21 .....	page 15
■ MPA 41 .....	page 17
■ MPA 81 .....	page 19

#### Self Contained Photoelectric Systems

■ Spacemaster 3000 .....	page 21
■ Spacemaster 6000 .....	page 25
■ Spacemaster 7000 .....	page 29
■ Spacemaster 8000 .....	page 33
■ Power Packs .....	page 37

#### General

■ Accessories .....	page 39
■ Fibre Optics .....	page 41
■ Glossary .....	page 45



## Remote Sensor Series

### Description

- Operation mode and max sensing range:  
**Thru beam:** 0-70 m  
**Diffuse proximity:** 0-3,5 m
- Optional sensor monitor LED
- Wide variety of housings
- High tolerance to hostile environments
- Cable or plug connections



The remote sensor series, which consists of a transmitter LT and receiver LR, is made to operate in conjunction with a Telco photoelectric amplifier from the PA or MPA programmes.

The series is available with optional power-(LR) and output-(LT) monitor LEDs for use with any Telco photoelectric amplifier which has the sensor LED drive feature incorporated.

The remote sensors are available in a wide range of housings, with either cable or plug connection, and may be used in thru beam or diffuse proximity mode.

### Technical Data

	LT	LR
Transmitter Diode	Ga Al As, (880 nm)	-
Photo Transistor	-	Silicon NPN
Cable Ø 4mm PVC Sleeves	2 x 0,25 mm <sup>2</sup>	1 x 0,25 mm <sup>2</sup> + shield
Min. cable bending radius	45 mm	

### Environmental Data

Vibration	10 – 55 Hz, 0,5 mm	
Shock	30 g	
Light immunity, @ 20° incidence	101 Series 100 Series 110/120 Series	>50 000 lux >80 000 lux >100 000 lux
Temperature, operation	- 25 to +65 °C	
Temperature, storage	- 40 to +80 °C	
Sealing Class	IP 67	
Approvals	CE	

Available Types									
	Series	Optical Angle	Connection		5 m Cable	15 m Cable	3 pin, M8 Plug	4 pin, M12 Plug	
			Housing Material	Housing Size					Order Reference
Transmitter	101	+/- 8°	Polycarbonate	Ø10	LT 101 AP25 5	LT 101 AP25 15	LT 101 AP25 T3	-	
			Nickel Plated Brass	M12 x 1	LT 101 TP25 5	LT 101 TP25 15	LT 101 TP25 T3	-	
			Stainless Steel		LT 101 TB25 5	LT 101 TB25 15	LT 101 TB25 T3	-	
			Polyester	□ 9,5 x 11,5	LT 101 SG 5*	LT 101 SG 15*	LT 101 SG T3	-	
			ABS	Ø12,7 (Snap Housing)	LT 101 S22 5*	LT 101 S22 15*	-	-	
Receiver		101	+/- 9°	Polycarbonate	Ø10	LR 101 AP25 5	LR 101 AP25 15	LR 101 AP25 T3	-
				Nickel Plated Brass	M12 x 1	LR 101 TP25 5	LR 101 TP25 15	LR 101 TP25 T3	-
				Stainless Steel		LR 101 TB25 5	LR 101 TB25 15	LR 101 TB25 T3	-
				Polyester	□ 9,5 x 11,5	LR 101 SG 5*	LR 101 SG 15*	LR 101 SG T3	-
				ABS	Ø12,7 (Snap Housing)	LR 101 S22 5*	LR 101 S22 15*	-	-

Transmitter	100	+/- 6°	Polycarbonate	Ø10	LT 100 AP38 5	LT 100 AP38 15	LT 100 AP38 T3	-	
			Nickel Plated Brass	M12 x 1	LT 100 TP38 5	LT 100 TP38 15	LT 100 TP38 T3	-	
			Stainless Steel		LT 100 TB38 5	LT 100 TB38 15	LT 100 TB38 T3	LT 100 TB58 J	
Receiver		100	+/- 9°	Polycarbonate	Ø10	LR 100 AP38 5	LR 100 AP38 15	LR 100 AP38 T3	-
				Nickel Plated Brass	M12 x 1	LR 100 TP38 5	LR 100 TP38 15	LR 100 TP38 T3	-
				Stainless Steel		LR 100 TB38 5	LR 100 TB38 15	LR 100 TB38 T3	LR 100 TB58 J
					LR 100 TS38 5	LR 100 TS38 15	LR 100 TS38 T3	LR 100 TS58 J	

Transmitter	110	+/- 8°	Polycarbonate	Ø10	LT 110 AP38 5	LT 110 AP38 15	LT 110 AP38 T3	-	
			Nickel Plated Brass	M12 x 1	LT 110 TP38 5	LT 110 TP38 15	LT 110 TP38 T3	-	
			Stainless Steel		LT 110 TB38 5	LT 110 TB38 15	LT 110 TB38 T3	LT 110 TB58 J	
Receiver		110	+/- 3°	Polycarbonate	Ø10	LR 110 AP38 5	LR 110 AP38 15	LR 110 AP38 T3	-
				Nickel Plated Brass	M12 x 1	LR 110 TP38 5	LR 110 TP38 15	LR 110 TP38 T3	-
				Stainless Steel		LR 110 TB38 5	LR 110 TB38 15	LR 110 TB38 T3	LR 110 TB58 J
					LR 110 TS38 5	LR 110 TS38 15	LR 110 TS38 T3	LR 110 TS58 J	

Transmitter	120	+/- 4°	Nickel Plated Brass	M18 x 1	-	LT 120 TB45 15	-	-
Receiver		+/- 2,5°	Nickel Plated Brass	M18 x 1	-	LR 120 TB45 15	-	-

**Note:** If the applicable amplifier has sensor LED-drive, add 'L' after the series number for sensor monitor LED eg. LT/LR 101L AP25 5.  
Sensors marked \* do not have this optional feature.  
Photo amplifiers to be ordered separately.

# Remote Sensor Series

## Applicable Photo Amplifiers and Ranges

Series	Operation Modes	Photoelectric Amplifiers									
		PA 01	PA 09	PA 10		PA 11	MPA 21	MPA 41		MPA 81	
				A	B			A/B	C/D	A/B	C/D
101	Thru-beam	8 m	5 m	11 m	-	-	-	-	-	-	-
	Diffuse Proximity	65 cm	45 cm	90 cm	-	-	-	-	-	-	-
100	Thru-beam	10 m	-	-	15 m	18 m	10 m	8 m	4 m	8 m	4 m
	Diffuse Proximity	75 cm	-	-	1,1 m	1,1 m	75 cm	65 cm	35 cm	65 cm	35 cm
110	Thru-beam	23 m	-	-	35 m	40 m	25 m	18 m	9 m	18 m	9 m
	Diffuse Proximity	1,6 m	-	-	2 m	2 m	1,6 m	1,3 m	70 cm	1,3 m	70 cm
120	Thru-beam	45 m	-	-	70 m	70 m	45 m	35 m	18 m	35 m	18 m
	Diffuse Proximity	2,5 m	-	-	3,5 m	3,5 m	2,5 m	2 m	1 m	2 m	1 m

Note: For ranges using fibre optics please refer to page 42.

## Connections

	Cable	M8 Plug/Cable	M12 Plug/Cable
Transmitter Signal	Red	Pin 1/Brown	Pin 1/Brown
Transmitter Ground	Black	Pin 3/Blue	Pin 3/Blue
Receiver Signal	Yellow	Pin 4/Black	Pin 4/Black
Receiver Ground	Shield	Pin 3/Blue	Pin 3/Blue

  

**3 pin, M8**

**4 pin, M12**

## Dimensions

### Series 101

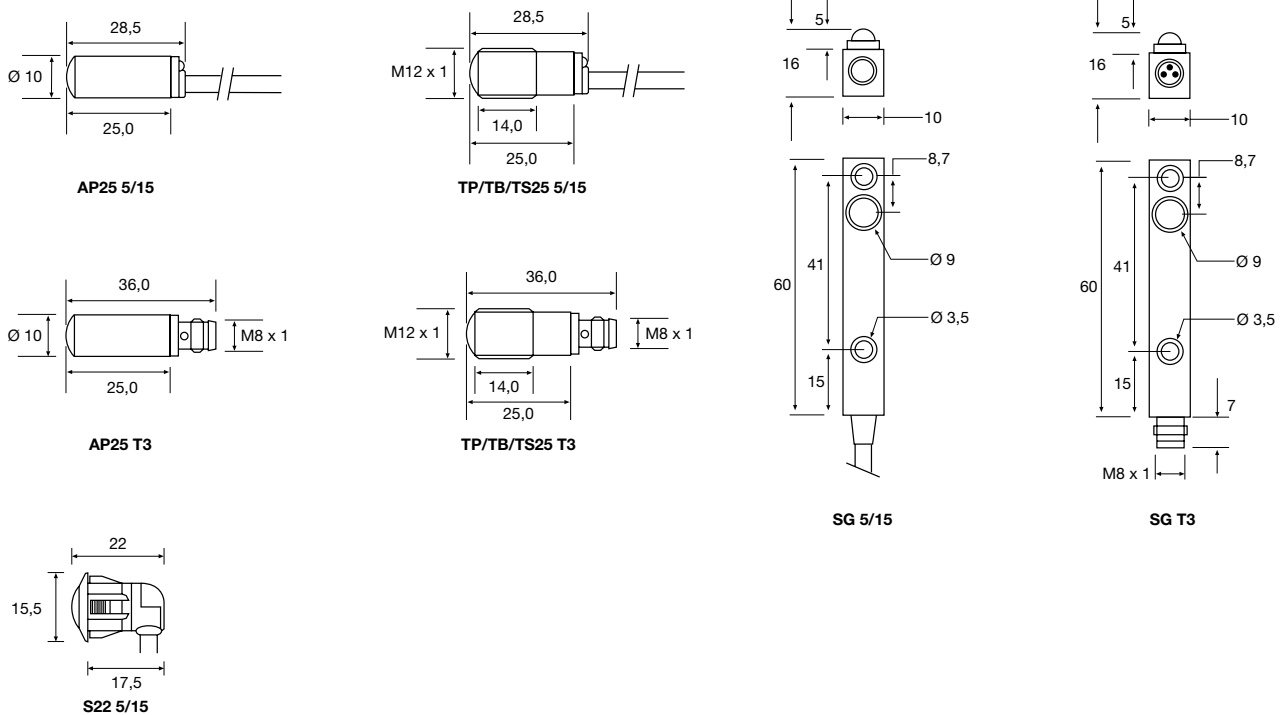

(Units in mm)

## Dimensions

### Series 100/110

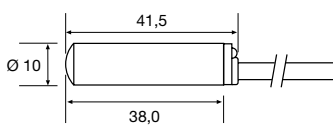

**AP38 5/15**

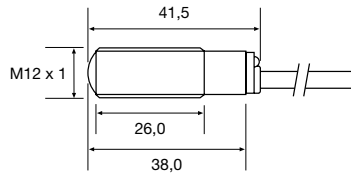

**TP/TB/TS38 5/15**

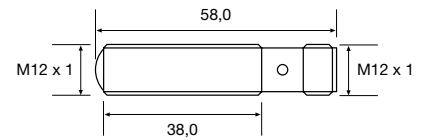

**TB/TS58 J**

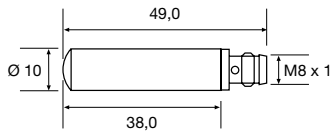

**AP38 T3**

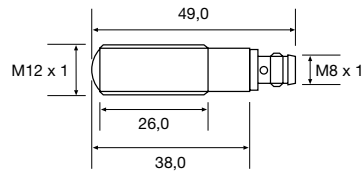

**TP/TB/TS38 T3**

(Units in mm)

### Series 120

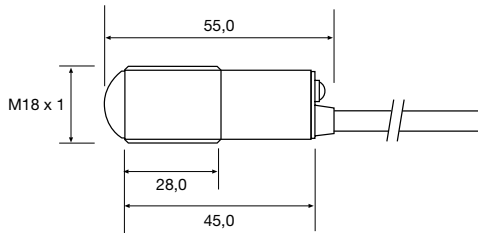

**TB45 15**

(Units in mm)

Telco reserves the right to change specifications without notice.

**Description**

- Operation mode and max sensing range:  
**Thru beam: 0-45 m**  
**Diffuse proximity: 0-2,5 m**
- 230 V ac, 115 V ac or 24 V ac/dc supply voltage
- Automatic and/or manual sensitivity adjustment
- Sensor LED-drive
- Adjustable on/off time delay
- 1 relay or 1 transistor output
- STF
- Switch selectable light or dark function
- Switch selectable long or short range
- Power, output and signal status indicators
- Test input
- 11-pole DIN socket connection



The PA 01 is to be used in conjunction with a set of remote transmitter LT and receiver LR from the series 101, 100, 110 or 120. This amplifier series offers a choice between automatic and/or manual sensitivity adjustment with or without a 0-10 sec on/off time delay via integral potentiometers located on the front panel of the amplifier. Output can be selected from either a relay or an NPN/PNP transistor output. Light or dark function and long or short range is switch selectable.

In automatic mode, set up is required. This is achieved by pressing the teach-in button located on the front panel. This unique feature ensures that the transmitting power level is adjusted according to the

application, thus achieving optimal hysteresis and excess gain. Once set up, the system will automatically compensate for moderate misalignment and contamination during operation. In manual mode, the teach-in button allows for an overall manual system test by temporarily disabling the transmitter. The sensor LED drive powers the optional monitor LEDs available on the remote sensors – output (LT) and power (LR).

The STF allows up to 3 identical systems to operate within a close distance of each other without optical cross talk as each system automatically maintains different transmitter frequencies.

Technical Data	
Supply voltage	115 V ac, 230 V ac (+/- 15%) 12-30 V ac or 12-36 V dc
Current consumption	Max. 2,5 VA
Output	Relay: 1 open / 1 close, 230 V ac / 3 A, 120 V ac / 5 A Transistor: 100 mA / 36 V dc
Power on indicator	Green LED
Output indicator	Yellow LED
Signal status indicator	Green LED
LR sensor failure indicator	-
LT sensor failure indicator	-
Sensor monitor LED drive	The green monitor LED on the receiver indicates 'Power ON' The yellow monitor LED on the transmitter indicates 'PA 01 output activated'
Hysteresis	Approx. 20 %
Operation frequency	12 Hz
Response time t <sub>ON</sub> / t <sub>OFF</sub>	40 ms / 40 ms
Delay t <sub>ON</sub> / t <sub>OFF</sub>	PA 01 C: 0 - 10 sec
Housing material	Noryl

Environmental Data	
Temperature, operation	- 10 to +55 °C
Temperature, storage	- 40 to +80 °C
Sealing class	IP 40
Approvals	CE

Available Types					
Model	Connection	Supply Voltage	12 – 30 V ac 12 – 36 V dc	115 V ac	230 V ac
		Output	Order Reference		
PA 01 A Automatic	11-pole DIN socket	Relay	PA 01 A 519	PA 01 A 511	PA 01 A 510
		NPN and PNP	PA 01 A 619	PA 01 A 611	PA 01 A 610
PA 01 B Automatic/Manual		Relay	PA 01 B 519	PA 01 B 511	PA 01 B 510
		NPN and PNP	PA 01 B 619	PA 01 B 611	PA 01 B 610
PA 01 C Automatic/Manual on/off delay		Relay	PA 01 C 519	PA 01 C 511	PA 01 C 510
		NPN and PNP	PA 01 C 619	PA 01 C 611	PA 01 C 610

Note: Remote sensors and 11-pole DIN sockets to be ordered separately.

Applicable Remote Sensors and Ranges		
Series	Thru Beam	Diffuse Proximity
101	8 m	65 cm
100	10 m	75 cm
110	23 m	2 m
120	45 m	2,5 m

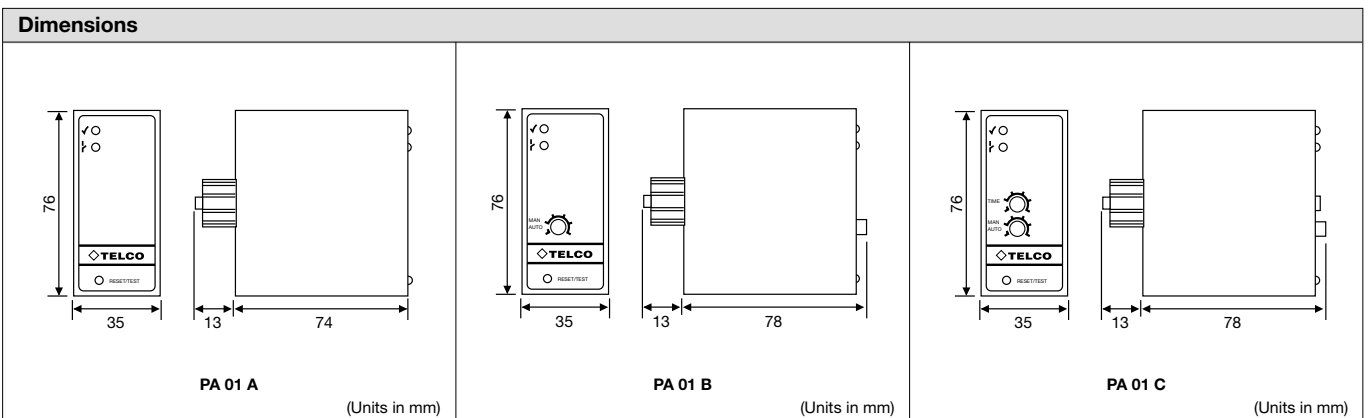
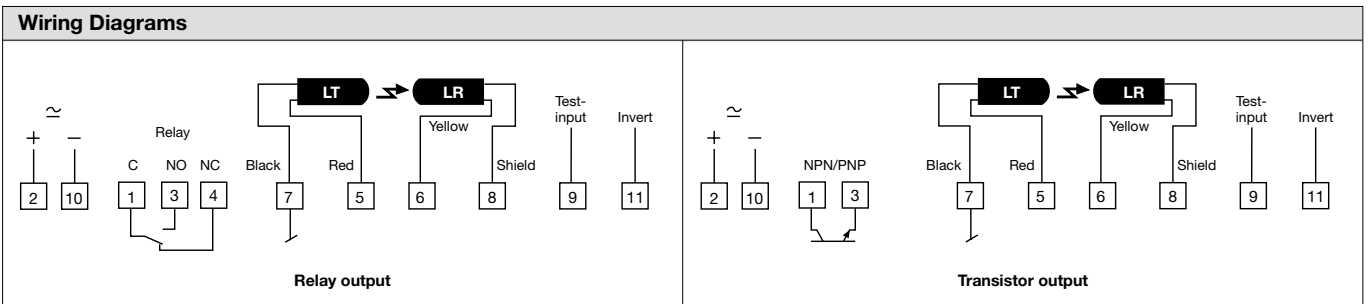

Telco reserves the right to change specifications without notice.

## Description

- Operation mode and max sensing range:  
**Thru beam: 5 m**  
**Diffuse proximity: 0-45 cm**
- 12 or 24 V dc supply voltage
- 1 relay output acc. to UNI 8612
- Power and output indicators
- Screw terminals connection



The PA 09 is to be used in conjunction with a set of remote transmitter LT and receiver LR from the series 101.

This amplifier series is low cost, designed especially for the elevator and door industries, offering a relay output, designed according to the UNI 8612 standard whereby 2 relays are mounted in series.

Technical Data	
Supply voltage	12 V dc or 24 V dc
Voltage tolerance @ 12 V dc	-10 / +20 %
Voltage tolerance @ 24 V dc	-15 / +20 %
Current consumption	Max. 2 VA
Output relay	24 V dc / 2A
Power on indicator	Green LED
Output indicator	Yellow LED
Signal status indicator	-
LR sensor failure indicator	-
LT sensor failure indicator	-
Sensor monitor LED drive	-
Hysteresis	Approx. 30 %
Operation frequency	10 Hz
Response time $t_{ON}$ / $t_{OFF}$	50 ms / 50 ms
Delay $t_{ON}$ / $t_{OFF}$	-
Housing material	Polystyrene

Environmental Data	
Temperature, operation	- 10 to +50 °C
Temperature, storage	- 40 to +80 °C
Sealing class	IP 40
Approvals	CE

**Available Types**

Model	Connection	Supply Voltage	12 V dc	24 V dc
		Output	Order Reference	
<b>PA 09 B</b>	Screw terminals	Relay	<b>PA 09 B 504</b>	<b>PA 09 B 503</b>

Note: Remote sensors to be ordered separately.

**Applicable Remote Sensors and Ranges**

Series	<b>Thru Beam</b>	<b>Diffuse Proximity</b>
<b>101</b>	5 m	45 cm

**Wiring Diagrams**

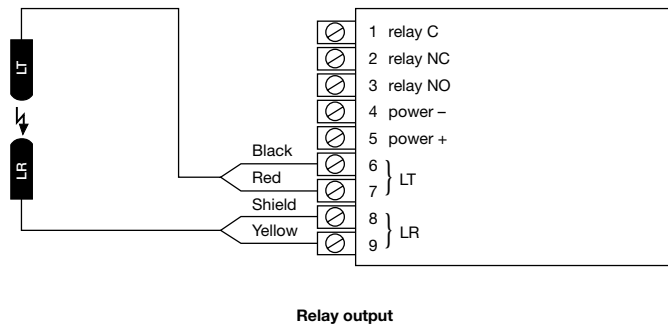

**Dimensions**

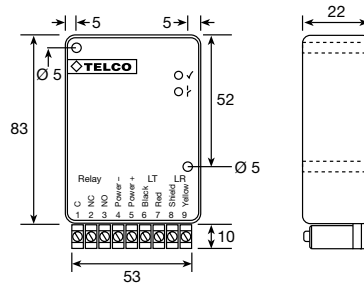

**PA 09 B**

(Units in mm)

Telco reserves the right to change specifications without notice.

**Description**



- **Operation mode and max sensing range:**  
**Thru beam:** 0-70 m  
**Diffuse proximity:** 0-3,5 m
- 230 V ac, 115 V ac, 24 V ac or 24 V dc supply voltage
- Manual sensitivity adjustment
- 1 relay or 1 transistor output
- Switch selectable light or dark function
- Switch selectable long or short range
- Power and output indicators
- 11-pole DIN socket connection



The PA 10 A is to be used in conjunction with a remote transmitter LT and receiver LR from series 101, whilst the PA 10 B is intended for use with series 100, 110, and 120. This amplifier series offers manual sensitivity adjustment via an integral potentiometer located on the front panel of the

amplifier. Output can be selected from either a relay or an NPN/PNP transistor output. Light or dark function and long or short range are switch selectable.

Technical Data	
Supply voltage	24 V dc, 24 V ac, 115 V ac or 230 V ac
Voltage tolerance	+/- 15 %
Current consumption	Max. 3,2 VA
Output	Relay Transistor
	1 open / 1 close, 250 V ac / 3 A, 120 V ac / 5 A
	40 mA / 30 V dc
Power on indicator	Green LED
Output indicator	Red LED
Signal level indicator	-
LR sensor failure indicator	-
LT sensor failure indicator	-
Sensor monitor LED drive	-
Hysteresis	Approx. 40 %
Operation frequency	10 Hz
Response time $t_{ON}$ / $t_{OFF}$	40 ms / 40 ms
Delay $t_{ON}$ / $t_{OFF}$	-
Housing material	Noryl

Environmental Data	
Temperature, operation	- 10 to +50 °C
Temperature, storage	- 40 to +80 °C
Sealing class	IP 40
Approvals	CE  

**Available Types**

Model	Connection	Supply Voltage	24 V dc	24 V ac	115 V ac	230 V ac
		Output	Order Reference			
PA 10 A	11-pole DIN socket	Relay	PA 10 A 513	PA 10 A 512	PA 10 A 511	PA 10 A 510
		NPN and PNP	PA 10 A 613	PA 10 A 612	PA 10 A 611	PA 10 A 610
PA 10 B		Relay	PA 10 B 513	PA 10 B 512	PA 10 B 511	PA 10 B 510
		NPN and PNP	PA 10 B 613	PA 10 B 612	PA 10 B 611	PA 10 B 610

Note: Remote sensors and 11-pole DIN sockets to be ordered separately.

**Applicable Remote Sensors and Ranges**

Series	Thru Beam	Diffuse Proximity
101 (only PA 10 A)	11 m	90 cm
100 (only PA 10 B)	15 m	1,1 m
110 (only PA 10 B)	35 m	2 m
120 (only PA 10 B)	70 m	3,5 m

**Wiring Diagrams**

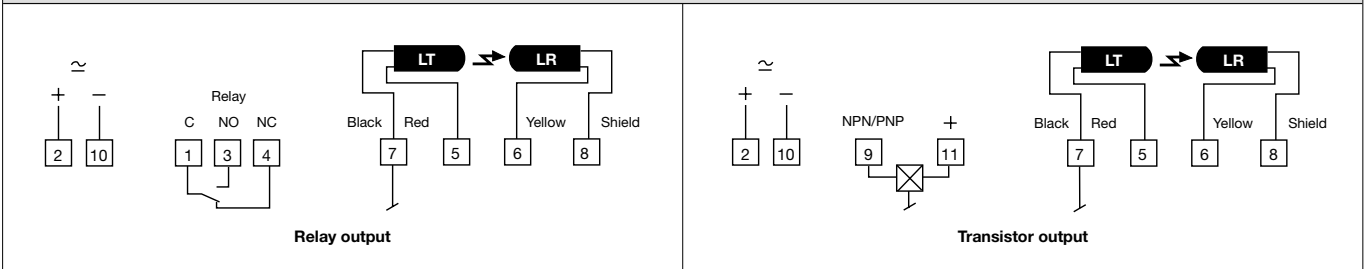

**Dimensions**

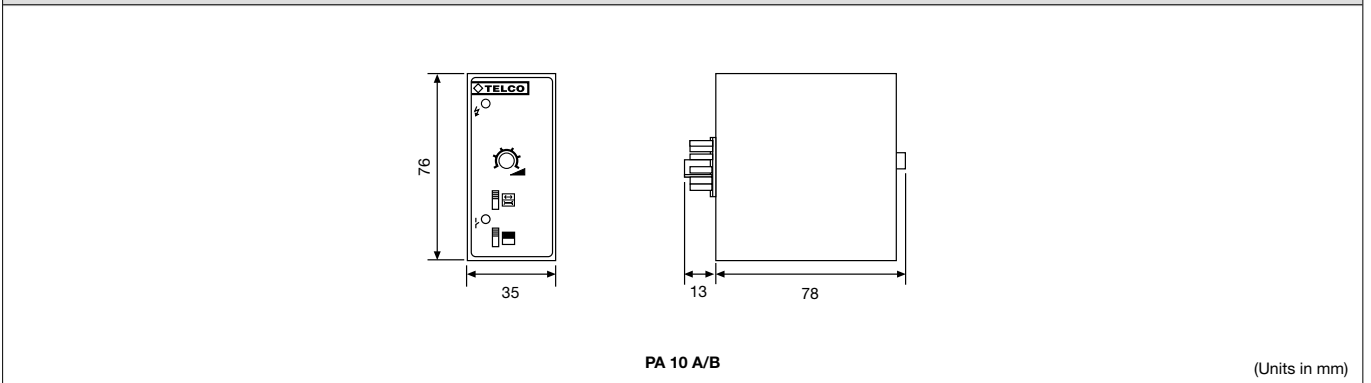

Telco reserves the right to change specifications without notice.

**Description**

- Operation mode and max sensing range:  
**Thru beam: 0-70 m**  
**Diffuse proximity: 0-3,5 m**
- 230 V ac, 115 V ac, 24 V ac or 24 V dc supply voltage
- Manual sensitivity adjustment
- Sensor LED-drive
- Automatic sensor test
- Adjustable on/off time delay
- 1 relay and/or 1 transistor output
- Switch selectable light or dark function
- Switch selectable long or short range
- Power, output and signal level indicators
- 11-pole DIN socket connection





The PA 11 is to be used in conjunction with a set of remote transmitter LT and receiver LR from the series 100, 110 and 120.

This amplifier series offers manual sensitivity adjustment via integral potentiometers located on the front panel of the amplifier output can be selected from either a relay and NPN or NPN and PNP transistor outputs with or without a 0-10 sec on/off time delay. Light or dark function and long or short range is switch selectable.

The microprocessor controlled sensor test ensures that the system will automatically detect and indicate a faulty transmitter or receiver – cable break or electrical failure – during operation, through the relevant LED located on the front panel. The sensor LED drive powers the optional monitor LEDs available on the remote sensors – output (LT) and power (LR).

Technical Data	
Supply voltage	24 V dc, 24 V ac, 115 V ac or 230 V ac
Voltage tolerance	+/- 15 %
Current consumption	Max. 3,5 VA
Output	Relay Transistor
	1 open / 1 close, 250 V ac / 3 A, 120 V ac / 5 A
	60 mA / 30 V dc
Power on indicator	Green LED
Output indicator	Yellow LED
Signal level indicator	Green LED
LR sensor failure indicator	Red LED
LT sensor failure indicator	Red LED
Sensor monitor LED drive	The green monitor LED on the receiver indicates 'Power ON' The yellow monitor LED on the transmitter indicates 'PA 11 output activated'
Hysteresis	Approx. 45 %
Operation frequency	20 Hz
Response time $t_{ON} / t_{OFF}$	35 ms / 35 ms
Delay $t_{ON} / t_{OFF}$	PA 11 A Adjustable 0 – 10 sec
Housing material	Noryl

Environmental Data	
Temperature, operation	-10 to +50 °C
Temperature, storage	-40 to +80 °C
Sealing class	IP 40
Approvals	CE  

**Available Types**

Model	Connection	Supply Voltage	24 V dc	24 V ac	115 V ac	230 V ac
		Output	Order Reference			
<b>PA 11 A</b> On/Off delay	11-pole DIN socket	Relay and NPN	<b>PA 11 A 303T</b>	<b>PA 11 A 302T</b>	<b>PA 11 A 301T</b>	<b>PA 11 A 300T</b>
		NPN and PNP	<b>PA 11 A 403T</b>	<b>PA 11 A 402T</b>	<b>PA 11 A 401T</b>	<b>PA 11 A 400T</b>
<b>PA 11 B</b>		Relay and NPN	<b>PA 11 B 303T</b>	<b>PA 11 B 302T</b>	<b>PA 11 B 301T</b>	<b>PA 11 B 300T</b>
		NPN and PNP	<b>PA 11 B 403T</b>	<b>PA 11 B 402T</b>	<b>PA 11 B 401T</b>	<b>PA 11 B 400T</b>

Note: Remote sensors and 11-pole DIN sockets to be ordered separately.

**Applicable Remote Sensors and Ranges**

Series	Thru Beam	Diffuse Proximity
<b>100</b>	18 m	1,1 m
<b>110</b>	40 m	2 m
<b>120</b>	70 m	3,5 m

**Wiring Diagrams**

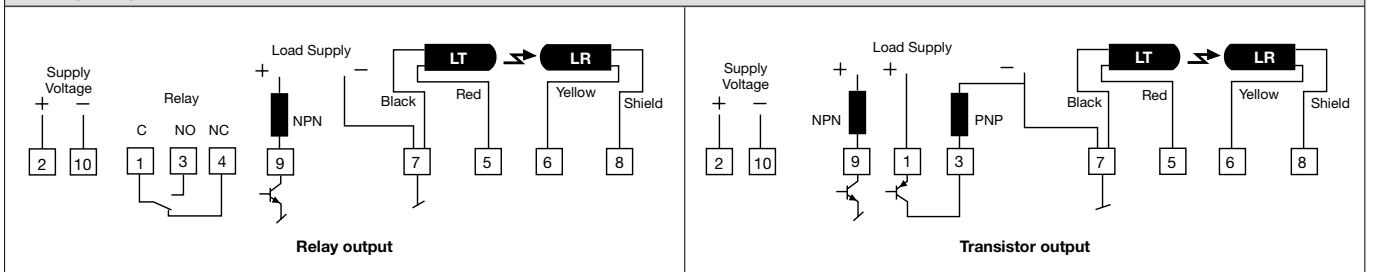

**Dimensions**

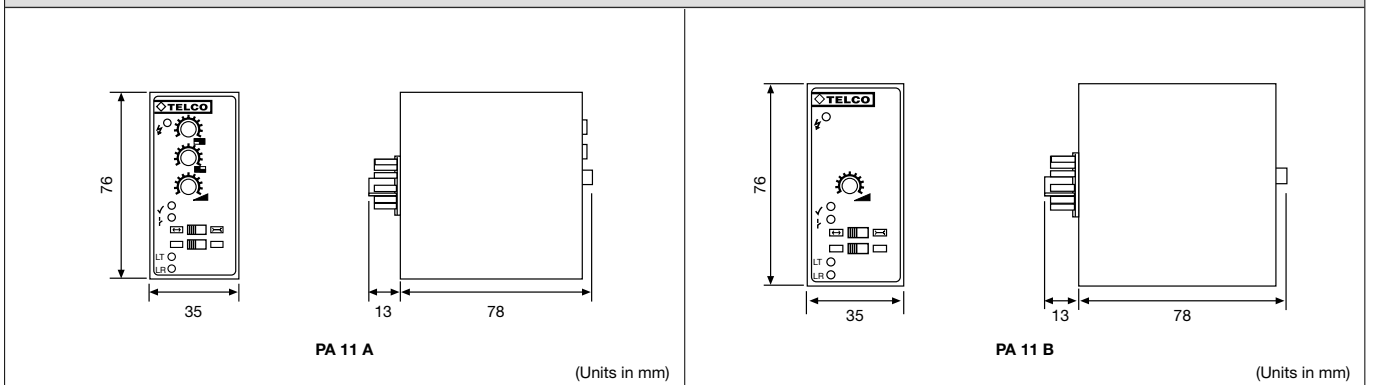

Telco reserves the right to change specifications without notice.

## Description

- Operation mode and max sensing range:  
**Thru beam:** 0-45 m  
**Diffuse proximity:** 0-2,5 m
- 230 V ac, 115 V ac, 24 V ac or 24 V dc supply voltage
- Manual sensitivity adjustment
- Adjustable on/off time delay
- 2 relays or 2 transistor outputs
- Power, output and signal level indicators
- Switch selectable light or dark function
- Switch selectable long or short range
- 11-pole DIN socket connection



The MPA 21 is to be used in conjunction with 2 sets of remote transmitters LT and receivers LR, from the series 100, 110 and 120.

The 2 channels operate independently of each other with their own set of remote transmitter and receiver. The multiplexing function ensures that optical cross talk between channels is prevented.

The series offers a choice between 2 individual relays or 2 individual

NPN/PNP transistor outputs, with or without an adjustable 0-3 sec on/off time delay.

This amplifier series offers manual sensitivity adjustment for each individual channel via integral potentiometers located on the front panel of the amplifier. Light or dark function and long or short range is switch selectable for each individual channel.

Technical Data		
Supply voltage		24 V dc, 24 V ac, 115 V ac or 230 V ac
Voltage tolerance		+/- 15 %
Current consumption		Max. 3 VA
Output	Relay	1 open / 1 close, 250 V ac / 3 A, 120 V ac / 5 A
	Transistor	40 mA / 30 V dc
Power on indicator		Green LED
Output indicator		Red LED
Signal level indicator		Green LED
LR sensor failure indicator		-
LT sensor failure indicator		-
Sensor monitor LED drive		-
Hysteresis		Approx. 35 %
Operation frequency	MPA 21 A	9 Hz
	MPA 21 B	11 Hz
Response time $t_{ON} / t_{OFF}$	MPA 21 A	55 ms / 55 ms
	MPA 21 B	45 ms / 45 ms
Delay $t_{ON} / t_{OFF}$	MPA 21 A	0 - 3 sec
Housing material		Noryl

Environmental Data		
Temperature, operation		- 10 to +50 °C
Temperature, storage		- 40 to +80 °C
Sealing class		IP 40
Approvals		CE TÜV SÜD

### Available Types

Model	Connection	Supply Voltage	24 V dc	24 V ac	115 V ac	230 V ac
		Output	Order Reference			
<b>MPA 21 A</b> On/Off delay	11-pole DIN socket	2 individual relays	<b>MPA 21 A 503</b>	<b>MPA 21 A 502</b>	<b>MPA 21 A 501</b>	<b>MPA 21 A 500</b>
		2 individual NPN/PNP	<b>MPA 21 A 603</b>	<b>MPA 21 A 602</b>	<b>MPA 21 A 601</b>	<b>MPA 21 A 600</b>
2 individual relays		<b>MPA 21 B 503</b>	<b>MPA 21 B 502</b>	<b>MPA 21 B 501</b>	<b>MPA 21 B 500</b>	
2 individual NPN/PNP		<b>MPA 21 B 603</b>	<b>MPA 21 B 602</b>	<b>MPA 21 B 601</b>	<b>MPA 21 B 600</b>	

Note: Remote sensors and 11-pole DIN sockets to be ordered separately.

### Applicable Remote Sensors and Ranges

Series	Thru Beam	Diffuse Proximity
<b>100</b>	10 m	75 cm
<b>110</b>	25 m	1,6 m
<b>120</b>	45 m	2,5 m

### Wiring Diagrams

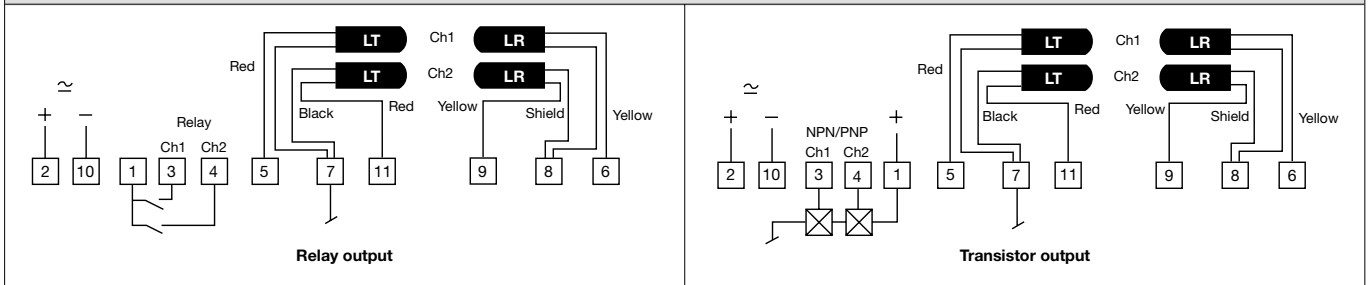

### Dimensions

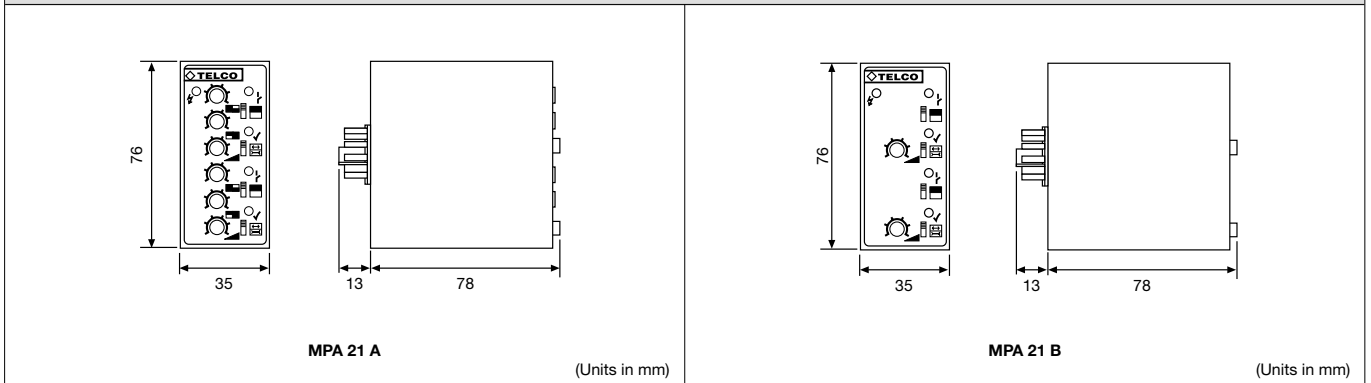

Telco reserves the right to change specifications without notice.

## Description

- Operation mode and max sensing range:  
**Thru beam: 0-35 m**  
**Diffuse proximity: 0-2 m**
- 230 V ac, 115 V ac, 24 V ac or 24 V dc supply voltage
- Manual sensitivity adjustment
- Adjustable on/off time delay
- 4 relays and/or 4 transistor individual outputs
- 1 relay and 1 transistor common output
- Switch selectable light or dark function
- Switch selectable long or short range
- Power, output and signal level indicators
- Screw terminals connection





The MPA 41 is to be used in conjunction with 4 sets of remote transmitters LT and receivers LR, from the series 100, 110 and 120.

The 4 channels operate independently of each other with their own set of remote transmitter and receiver. The multiplexing function ensures that optical cross talk between channels is prevented. The series offers a choice between 4 individual relays and/or 4 individual NPN/PNP

transistor outputs, or 1 common relay and 1 common transistor output which features an adjustable 0-10 sec on/off time delay.

This amplifier series offers manual sensitivity adjustment for each individual channel via integral potentiometers located on the front panel of the amplifier. Light or dark function and long or short range is switch selectable for each individual channel.

Technical Data		
Supply voltage		24 V dc, 24 V ac, 115 V ac or 230 V ac
Voltage tolerance		+/- 15 %
Current consumption		Max. 6,5 VA
Output	Relay	1 open / 1 close, 250 V ac / 3 A, 120 V ac / 5 A
	Transistor	40 mA / 30 V dc
Power on indicator		Green LED
Output indicator		Red LED
Signal level indicator		Green LED
LR sensor failure indicator		-
LT sensor failure indicator		-
Sensor monitor LED drive		-
Hysteresis		Approx. 35 %
Operation frequency	MPA 41 A / B	10 Hz
	MPA 41 C / D	25 Hz
Response time $t_{ON} / t_{OFF}$	MPA 41 A / B	50 ms / 50 ms
	MPA 41 C / D	20 ms / 20 ms
Delay $t_{ON} / t_{OFF}$	MPA 41 B / D	0 - 10 sec
Housing material		Noryl

Environmental Data		
Temperature, operation		- 10 to +50 °C
Temperature, storage		- 40 to +80 °C
Sealing class		IP 30
Approvals		CE  

Available Types						
Model	Connection	Supply Voltage	24 V dc	24 V ac	115 V ac	230 V ac
		Output	Order Reference			
MPA 41 A	Screw terminals	4 individual NPN/PNP	MPA 41 A 603	MPA 41 A 602	MPA 41 A 601	MPA 41 A 600
		4 individual relays and 4 individual NPN/PNP	MPA 41 A 703	MPA 41 A 702	MPA 41 A 701	MPA 41 A 700
MPA 41 B On/Off delay		1 common relay and 1 common NPN/PNP	MPA 41 B 703	MPA 41 B 702	MPA 41 B 701	MPA 41 B 700
MPA 41 C		4 individual NPN/PNP	MPA 41 C 603	MPA 41 C 602	MPA 41 C 601	MPA 41 C 600
		4 individual relays and 4 individual NPN/PNP	MPA 41 C 703	MPA 41 C 702	MPA 41 C 701	MPA 41 C 700
MPA 41 D On/Off delay		1 common relay and 1 common NPN/PNP	MPA 41 D 703	MPA 41 D 702	MPA 41 D 701	MPA 41 D 700

Note: Remote sensors to be ordered separately.

Applicable Remote Sensors and Ranges		
Series	Thru Beam	Diffuse Proximity
<b>MPA 41 A/B</b>		
100	8 m	65 cm
110	18 m	1,3 m
120	35 m	2 m
<b>MPA 41 C/D</b>		
100	4 m	35 cm
110	9 m	70 cm
120	18 m	1 m

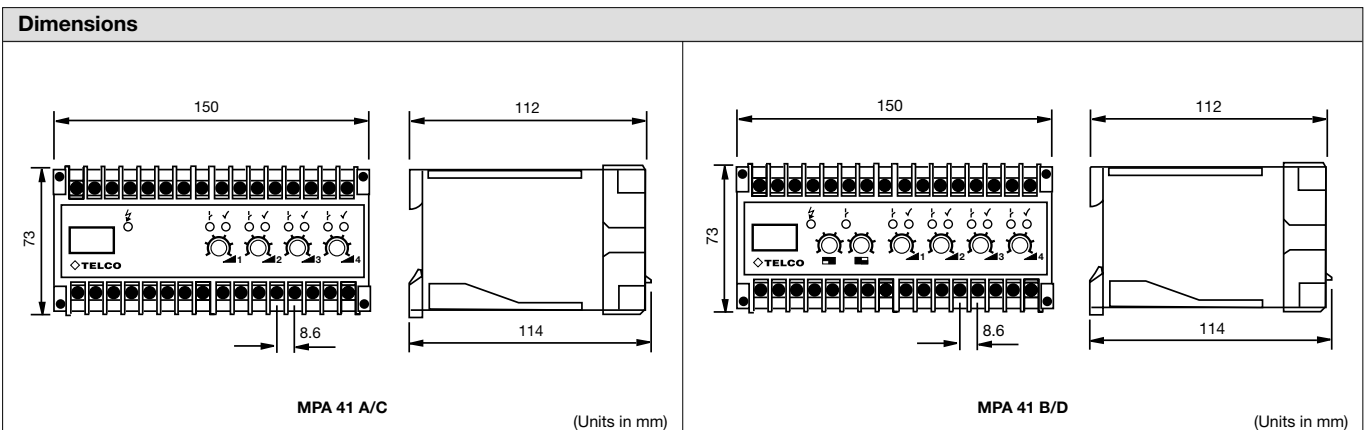
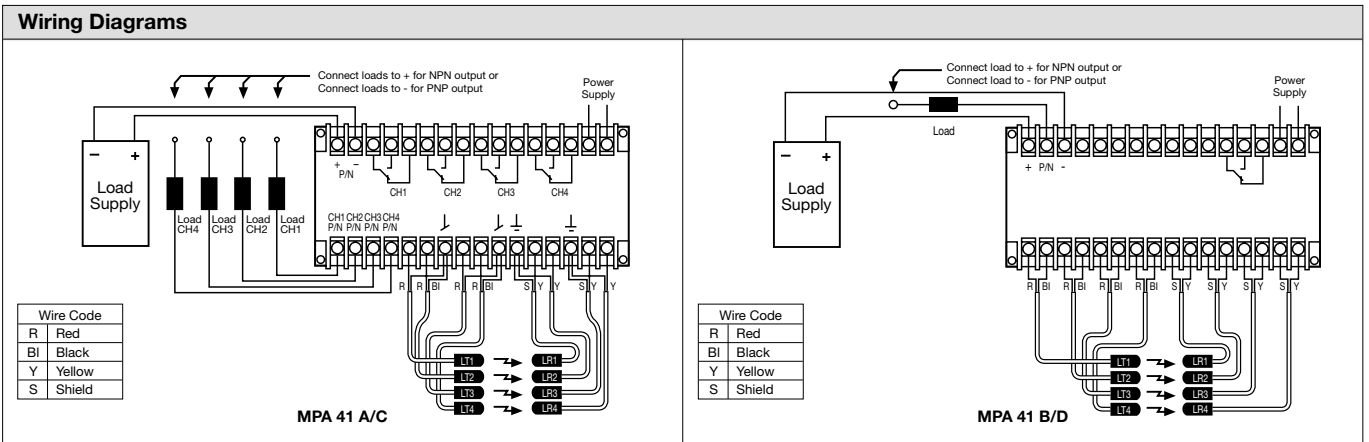

Telco reserves the right to change specifications without notice.

**Description**

- Operation mode and max sensing range:  
**Thru beam: 0-35 m**  
**Diffuse proximity: 0-2 m**
- 230 V ac, 115 V ac, 24 V ac or 24 V dc supply voltage
- Manual sensitivity adjustment
- Adjustable on/off time delay
- 8 relays or 8 transistor individual outputs
- 1 relay and 1 transistor common output
- Switch selectable light or dark function
- Switch selectable long or short range
- Power, output and signal level indicators
- Screw terminals connection

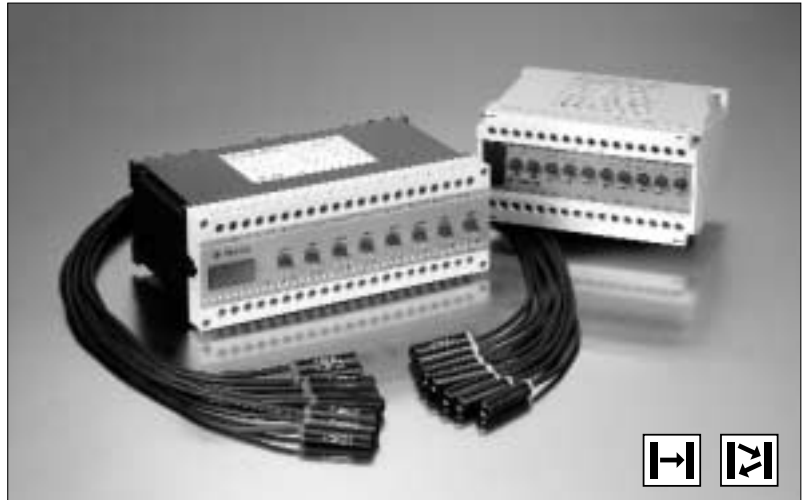



The MPA 81 is to be used in conjunction with 8 sets of remote transmitters LT and receivers LR, from the series 100, 110 and 120.

The 8 channels operate independently of each other with their own set of remote transmitter and receiver. The multiplexing function ensures that optical cross talk between channels is prevented. The series offers a choice between 8 individual relays or 8 individual NPN/PNP transistor

outputs, or 1 common relay and 1 common NPN/PNP transistor output which has an adjustable 0-10 sec on-off time delay.

This amplifier series offers manual sensitivity adjustment for each individual channel, via integral potentiometers located on the front panel of the amplifier. Light or dark function and long or short range is switch selectable for each individual channel.

<b>Technical Data</b>		
Supply voltage		24 V dc, 24 V ac, 115 V ac or 230 V ac
Voltage tolerance		+/- 15 %
Current consumption		Max. 6,5 VA
Output	Relay	1 open / 1 close, 250 V ac / 3 A, 120 V ac / 5 A
	Transistor	40 mA / 30 V dc
Power on indicator		Green LED
Output indicator		Red LED
Signal level indicator		Green LED
LR sensor failure indicator		-
LT sensor failure indicator		-
Sensor monitor LED drive		-
Hysteresis		Approx. 35 %
Operation frequency	MPA 81 A /B	5 Hz
	MPA 81 C/D	13 Hz
Response time $t_{ON} / t_{OFF}$	MPA 81 A/B	90 ms / 90 ms
	MPA 81 C/D	36 ms / 36 ms
Delay $t_{ON} / t_{OFF}$	MPA 81 B/D	0 - 10 sec
Housing material		Noryl

<b>Environmental Data</b>		
Temperature, operation		- 10 to +50 °C
Temperature, storage		- 40 to +80 °C
Sealing class		IP 30
Approvals		CE  

Available Types						
Model	Connection	Supply Voltage	24 V dc	24 V ac	115 V ac	230 V ac
		Output	Order Reference			
MPA 81 A	Screw terminals	8 individual relays	MPA 81 A 503	MPA 81 A 502	MPA 81 A 501	MPA 81 A 500
		8 individual NPN/PNP	MPA 81 A 603	MPA 81 A 602	MPA 81 A 601	MPA 81 A 600
MPA 81 B On/Off delay		1 common relay and 1 common NPN/PNP	MPA 81 B 703	MPA 81 B 702	MPA 81 B 701	MPA 81 B 700
		MPA 81 C	8 individual relays	MPA 81 C 503	MPA 81 C 502	MPA 81 C 501
8 individual NPN/PNP			MPA 81 C 603	MPA 81 C 602	MPA 81 C 601	MPA 81 C 600
MPA 81 D On/Off delay		1 common relay and 1 common NPN/PNP	MPA 81 D 703	MPA 81 D 702	MPA 81 D 701	MPA 81 D 700

Note: Remote sensors to be ordered separately.

Applicable Remote Sensors and Ranges		
Series	Thru Beam	Diffuse Proximity
<b>MPA 81 A/B</b>		
100	8 m	65 cm
110	18 m	1,3 m
120	35 m	2 m
<b>MPA 81 C/D</b>		
100	4 m	35 cm
110	9 m	70 cm
120	18 m	1 m

## Wiring Diagrams

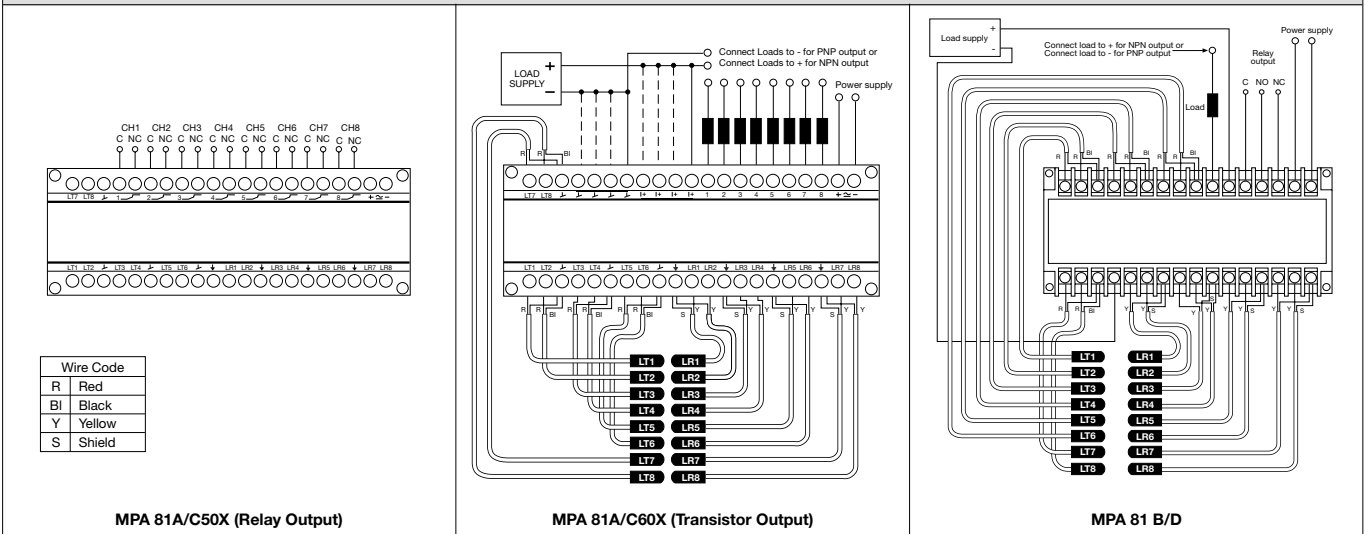

## Dimensions

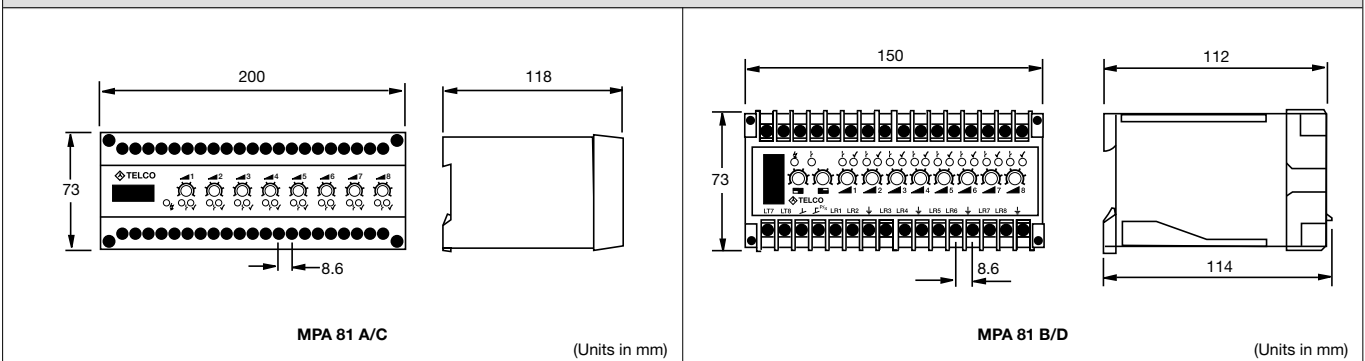

Telco reserves the right to change specifications without notice.

**Description**

- Operation mode and max sensing range:  
Thru beam: 0-6 m
- Cable or plug connection
- Sensitivity adjustment via control input
- Wide variety of housings
- Output indicator
- High tolerance to hostile environments
- 10 – 30 V dc supply voltage
- 3 wire, NPN or PNP transistor output



The 3000 series consists of a low cost self-contained transmitter SMT, and a receiver SMR, which are to be used in thru beam mode. The complete series is available in a wide range of housings with either cable or plug connection.

The control input in the SMT may be used for either disabling or enabling the transmitting power temporarily for test purpose, multiplexing applications or as a gradual regulation of the transmitting power level. Both the transmitter and receiver are protected against reverse polarity.

The SMR is supplied with a 10-30 V dc supply voltage with a 3 wire, NPN or PNP transistor output with a choice between light or dark function.

Technical Data		
	SMT	SMR
Supply voltage	10 – 30 V dc	
Voltage ripple	20%	
Reverse polarity protected	Yes	
Short circuit protected	–	
Current consumption	30 mA @ 30 V dc	23 mA @ 30 V dc
Maximum output load	–	100 mA
Maximum residual voltage	–	2,1 V
Maximum operation frequency	–	100 Hz
Response time $t_{ON}$ / $t_{OFF}$	–	7 ms / 4 ms
Power on indicator	–	–
Output indicator	–	Red LED
Hysteresis	–	Approx. 30 %
Transmitter diode	Ga Al As (880 nm)	–
Opening angle	–	+/- 9°
Emission angle	+/- 12°	–



Environmental Data	
Vibration	10 – 55 Hz, 0,5 mm
Shock	30 g
Light immunity, @ 20° incidence	>20 000 lux
Temperature, operation	–20 to +50 °C
Temperature, storage	–40 to +80 °C
Sealing class	IP 67
Approvals	CE

Available Types										
	Type	Control Feature	Output	Connection		2,5 m Cable	5 m Cable	3 pin, M8 Plug	4 pin, M12 Plug	Range
				Housing Material	Housing Size					
Transmitter	3000C	Adjustable range and test input		Polycarbonate	Ø10	SMT 3000C AP 2,5	SMT 3000C AP 5	SMT 3000C AP T3	-	0-6 metres
				Nickel Plated Brass	M12 x 1	SMT 3000C TP 2,5	SMT 3000C TP 5	SMT 3000C TP T3	-	
						SMT 3000C TB 2,5	SMT 3000C TB 5	SMT 3000C TB T3	SMT 3000C TB J	
				Polyester	□ 9,5 x 11,5	SMT 3000C SG 2,5	SMT 3006C SG 5	SMT 3000C SG T3	-	
ABS	Ø12,7 (Snap Housing)	SMT 3000C S 2,5	SMT 3000C S 5	-	-					

	Type	Control Feature	Output	Connection		2,5 m Cable	5 m Cable	3 pin, M8 Plug	4 pin, M12 Plug	Range	
				Housing Material	Housing Size						Order Reference
Receiver	3006	NPN, NC (light operated)		Polycarbonate	Ø10	SMR 3006 AP 2,5	SMR 3006 AP 5	SMR 3006 AP T3	-	6 metres	
				Nickel Plated Brass	M12 x 1	SMR 3006 TP 2,5	SMR 3006 TP 5	SMR 3006 TP T3	-		
						SMR 3006 TB 2,5	SMR 3006 TB 5	SMR 3006 TB T3	SMR 3006 TB J		
				Polyester	□ 9,5 x 11,5	SMR 3006 SG 2,5	SMR 3006 SG 5	SMR 3006 SG T3	-		
	ABS	Ø12,7 (Snap Housing)	SMR 3006 S 2,5	SMR 3006 S 5	-	-					
	3106	NPN, NO (dark operated)			Polycarbonate	Ø10	SMR 3106 AP 2,5	SMR 3106 AP 5	SMR 3106 AP T3		-
					Nickel Plated Brass	M12 x 1	SMR 3106 TP 2,5	SMR 3106 TP 5	SMR 3106 TP T3		-
							SMR 3106 TB 2,5	SMR 3106 TB 5	SMR 3106 TB T3		SMR 3106 TB J
					Polyester	□ 9,5 x 11,5	SMR 3106 SG 2,5	SMR 3106 SG 5	SMR 3106 SG T3		-
	ABS	Ø12,7 (Snap Housing)	SMR 3106 S 2,5	SMR 3106 S 5	-	-					
	3206	PNP, NC (light operated)			Polycarbonate	Ø10	SMR 3206 AP 2,5	SMR 3206 AP 5	SMR 3206 AP T3		-
					Nickel Plated Brass	M12 x 1	SMR 3206 TP 2,5	SMR 3206 TP 5	SMR 3206 TP T3		-
SMR 3206 TB 2,5							SMR 3206 TB 5	SMR 3206 TB T3	SMR 3206 TB J		
Polyester					□ 9,5 x 11,5	SMR 3206 SG 2,5	SMR 3206 SG 5	SMR 3206 SG T3	-		
ABS	Ø12,7 (Snap Housing)	SMR 3206 S 2,5	SMR 3206 S 5	-	-						
3306	PNP, NO (dark operated)			Polycarbonate	Ø10	SMR 3306 AP 2,5	SMR 3306 AP 5	SMR 3306 AP T3	-		
				Nickel Plated Brass	M12 x 1	SMR 3306 TP 2,5	SMR 3306 TP 5	SMR 3306 TP T3	-		
						SMR 3306 TB 2,5	SMR 3306 TB 5	SMR 3306 TB T3	SMR 3306 TB J		
				Polyester	□ 9,5 x 11,5	SMR 3306 SG 2,5	SMR 3306 SG 5	SMR 3306 SG T3	-		
ABS	Ø12,7 (Snap Housing)	SMR 3306 S 2,5	SMR 3306 S 5	-	-						

Connections			
	Cable	M8 Plug/Cable	M12 Plug/Cable
Supply +	Brown	Pin 1/Brown	Pin 1/Brown
Supply -	Blue	Pin 3/Blue	Pin 3/Blue
SMT control	Black	Pin 4/Black	Pin 4/Black
SMR output	Black	Pin 4/Black	Pin 3/Black

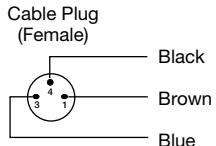

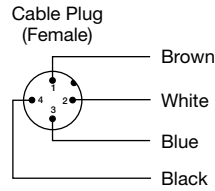
<p><b>3 pin, M8</b></p> <p>Sensor Plug (Male)</p> 		<p>Cable Plug (Female)</p> 	
<p><b>4 pin, M12</b></p> <p>Sensor Plug (Male)</p> 		<p>Cable Plug (Female)</p> 	

Wiring Diagrams

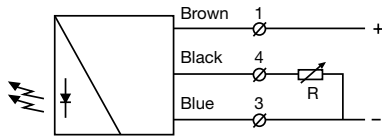

SMT 3000C 0-6 m

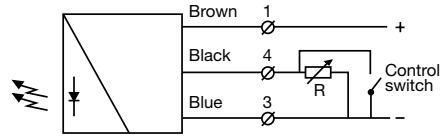

SMT 3000C 0-6 m variable range and ON/OFF switch for transmitting power

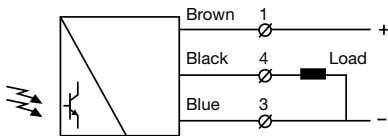

SMR 3206/3306

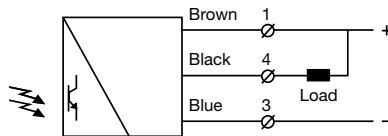

SMR 3006/3106

Dimensions

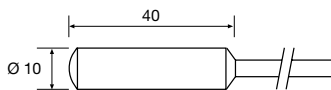

AP 2,5/5

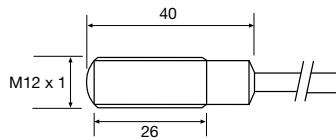

TP/TB 2,5/5

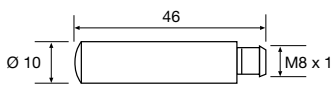

AP T3

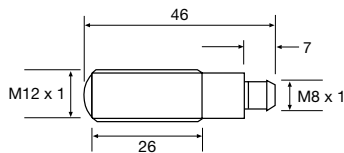

TP/TB T3

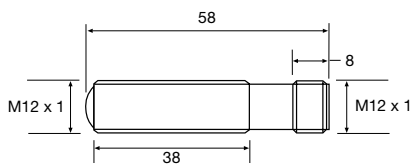

TB J

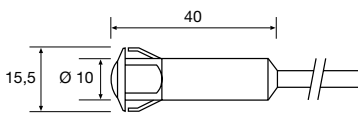

S 2,5/5

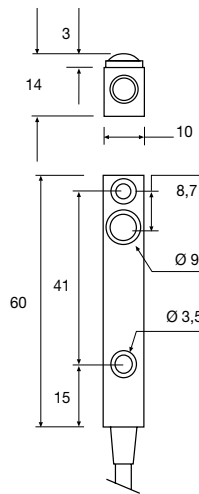

SG 2,5/5

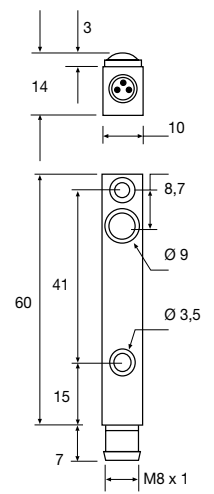

SG T3

(Units in mm)

Telco reserves the right to change specifications without notice.



**Description**

- Operation mode and max sensing range:  
Thru beam: 0-6 m
- Cable or plug connection
- Sensitivity adjustment via control input
- Wide variety of housings
- Power and output indicators
- High tolerance to hostile environments
- 10 – 30 V dc supply voltage
- 3 wire, NPN or PNP output or  
4 wire, NPN/PNP opto isolated output
- 5 or 0,5 ms response time
- Low current consumption

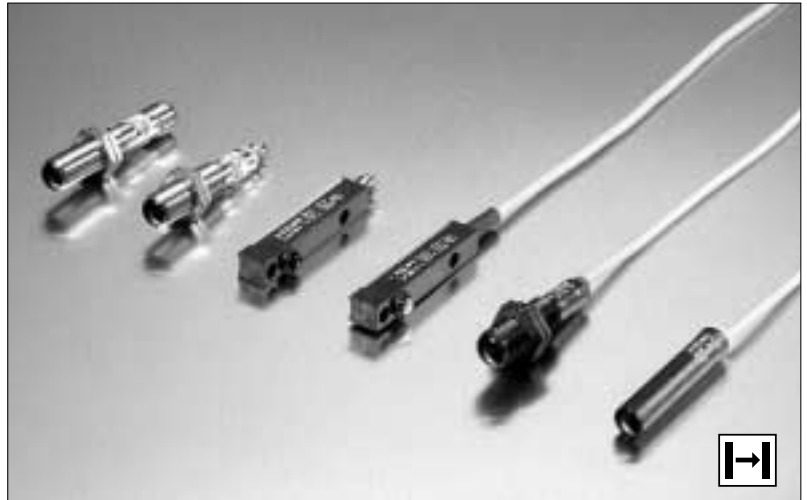

The 6000 series consists of a self-contained transmitter SMT, and a receiver SMR, which are to be used in thru beam mode. The complete series is available in a wide range of housings with either plug or cable connection.

The SMR is supplied with a 10-32 V dc supply voltage with either a 3 wire, NPN or PNP or as a 4 wire, NPN/PNP opto-isolated transistor output with a choice between light or dark function. The SMR is available with either a 0.5 ms response time with a 2 metre range, or with a 5 ms

response time with a 6 metre range. The control input in the SMT may be used for either disabling or enabling the transmitting power temporarily for test purpose, multiplexing applications or as a gradual regulation of the transmitting power level.

Both the transmitter and receiver are protected against reverse polarity of power supplies, control input and output signals. The output is also protected against short circuit and inductive loads.

Technical Data			
	SMT	SMR	
	-	6x00	6x01
Supply voltage	10 – 30 V dc		
Voltage ripple	15 %		
Reverse polarity protected	Yes		
Short circuit protected	Yes		
Current consumption	10 mA @ 32 V dc	10 mA @ 32 V dc	
Maximum output load	-	100 mA	
Maximum residual voltage	-	2,5 V	
Maximum operation frequency	-	100 Hz	1000 Hz
Response time $t_{ON} / t_{OFF}$	-	5 ms / 5 ms	0,5 ms / 0,5 ms
Power on indicator	Green LED	-	
Output indicator	-	Yellow LED	
Hysteresis	-	Approx. 30%	
Transmitter diode	Ga Al As (880 nm)	-	
Opening angle	-	+/- 6°	
Emission angle	+/- 10°	-	

Environmental Data	
Vibration	10 – 55 Hz, 0,5 mm
Shock	30 g
Light immunity, @ 5° incidence	>50 000 lux
Temperature, operation	-20 to +60 °C
Temperature, storage	-40 to +80 °C
Sealing class	IP 67
Approvals	CE

Available Types										
	Type	Control Feature	Output	Connection		5 m Cable	3 pin, M8 Plug	4 pin, M8 Plug	4 pin, M12 Plug	Range
				Housing Material	Housing Size					
Transmitter	6000	Adjustable range and test input		Polycarbonate	Ø10	SMT 6000 AP 5	SMT 6000 AP T3	-	-	1 – 6 metres
					M12 x 1	SMT 6000 TP 5	SMT 6000 TP T3	-	-	
				Stainless Steel	Ø10	SMT 6000 AS 5	SMT 6000 AS T3	SMT 6000 AS T4	-	
					M12 x 1	SMT 6000 TS 5	SMT 6000 TS T3	SMT 6000 TS T4	SMT 6000 TS J	
Polyester	□ 9,5 x 11,5	SMT 6000 SG 5	SMT 6000 SG T3	-	-					

Receiver	6000	NPN, NC (light operated)	Polycarbonate	Ø10	SMR 6000 AP 5	SMR 6000 AP T3	-	-	6 metres
				M12 x 1	SMR 6000 TP 5	SMR 6000 TP T3	-	-	
			Stainless Steel	Ø10	SMR 6000 AS 5	SMR 6000 AS T3	-	-	
				M12 x 1	SMR 6000 TS 5	SMR 6000 TS T3	-	SMR 6000 TS J	
	Polyester	□ 9,5 x 11,5	SMR 6000 SG 5	SMR 6000 SG T3	-	-			
	6100	NPN, NO (dark operated)	Polycarbonate	Ø10	SMR 6100 AP 5	SMR 6100 AP T3	-	-	
				M12 x 1	SMR 6100 TP 5	SMR 6100 TP T3	-	-	
			Stainless Steel	Ø10	SMR 6100 AS 5	SMR 6100 AS T3	-	-	
				M12 x 1	SMR 6100 TS 5	SMR 6100 TS T3	-	SMR 6100 TS J	
	Polyester	□ 9,5 x 11,5	SMR 6100 SG 5	SMR 6100 SG T3	-	-			
	6200	PNP, NC (light operated)	Polycarbonate	Ø10	SMR 6200 AP 5	SMR 6200 AP T3	-	-	
				M12 x 1	SMR 6200 TP 5	SMR 6200 TP T3	-	-	
			Stainless Steel	Ø10	SMR 6200 AS 5	SMR 6200 AS T3	-	-	
				M12 x 1	SMR 6200 TS 5	SMR 6200 TS T3	-	SMR 6200 TS J	
	Polyester	□ 9,5 x 11,5	SMR 6200 SG 5	SMR 6200 SG T3	-	-			
	6300	PNP, NO (dark operated)	Polycarbonate	Ø10	SMR 6300 AP 5	SMR 6300 AP T3	-	-	
				M12 x 1	SMR 6300 TP 5	SMR 6300 TP T3	-	-	
			Stainless Steel	Ø10	SMR 6300 AS 5	SMR 6300 AS T3	-	-	
				M12 x 1	SMR 6300 TS 5	SMR 6300 TS T3	-	SMR 6300 TS J	
	Polyester	□ 9,5 x 11,5	SMR 6300 SG 5	SMR 6300 SG T3	-	-			
	6400	NPN/PNP, NO (dark operated)	Stainless Steel	Ø10	-	-	SMR 6400 AS T4	-	
				M12 x 1	-	-	SMR 6400 TS T4	SMR 6400 TS J	
	6500	NPN/PNP, NC (light operated)	Stainless Steel	Ø10	-	-	SMR 6500 AS T4	-	
				M12 x 1	-	-	SMR 6500 TS T4	SMR 6500 TS J	

	Type	Control Feature	Output	Connection		5m Cable	3 pin, M8 Plug	4 pin, M8 Plug	4 pin, M12 Plug	Range
				Housing Material	Housing Size					
<b>Receiver</b>	<b>6001</b>	NPN, NC (light operated)	Polycarbonate	Ø10	SMR 6001 AP 5	SMR 6001 AP T3	-	-	2 metres	
				M12 x 1	SMR 6001 TP 5	SMR 6001 TP T3	-	-		
			Stainless Steel	Ø10	SMR 6001 AS 5	SMR 6001 AS T3	-	-		
				M12 x 1	SMR 6001 TS 5	SMR 6001 TS T3	-	SMR 6001 TS J		
	Polyester		□ 9,5 x 11,5	SMR 6001 SG 5	SMR 6001 SG T3	-	-			
	<b>6101</b>		NPN, NO (dark operated)	Polycarbonate	Ø10	SMR 6101 AP 5	SMR 6101 AP T3	-		-
					M12 x 1	SMR 6101 TP 5	SMR 6101 TP T3	-		-
				Stainless Steel	Ø10	SMR 6101 AS 5	SMR 6101 AS T3	-		-
		M12 x 1			SMR 6101 TS 5	SMR 6101 TS T3	-	SMR 6101 TS J		
	Polyester	□ 9,5 x 11,5		SMR 6101 SG 5	SMR 6101 SG T3	-	-			
	<b>6201</b>	PNP, NC (light operated)		Polycarbonate	Ø10	SMR 6201 AP 5	SMR 6201 AP T3	-	-	
					M12 x 1	SMR 6201 TP 5	SMR 6201 TP T3	-	-	
				Stainless Steel	Ø10	SMR 6201 AS 5	SMR 6201 AS T3	-	-	
			M12 x 1		SMR 6201 TS 5	SMR 6201 TS T3	-	SMR 6201 TS J		
	Polyester		□ 9,5 x 11,5	SMR 6201 SG 5	SMR 6201 SG T3	-	-			
	<b>6301</b>		PNP, NO (dark operated)	Polycarbonate	Ø10	SMR 6301 AP 5	SMR 6301 AP T3	-	-	
					M12 x 1	SMR 6301 TP 5	SMR 6301 TP T3	-	-	
				Stainless Steel	Ø10	SMR 6301 AS 5	SMR 6301 AS T3	-	-	
		M12 x 1			SMR 6301 TS 5	SMR 6301 TS T3	-	SMR 6301 TS J		
	Polyester	□ 9,5 x 11,5		SMR 6301 SG 5	SMR 6301 SG T3	-	-			
<b>6401</b>	NPN/PNP, NO (dark operated)	Stainless Steel		Ø10	-	-	SMR 6401 AS T4	SMR 6401 AS J		
				M12 x 1	-	-	SMR 6401 TS T4	SMR 6401 TS J		
<b>6501</b>				NPN/PNP, NC (light operated)	Stainless Steel	Ø10	-	-	SMR 6501 AS T4	SMR 6501 AS J
			M12 x 1			-	-	SMR 6501 TS T4	SMR 6501 TS J	

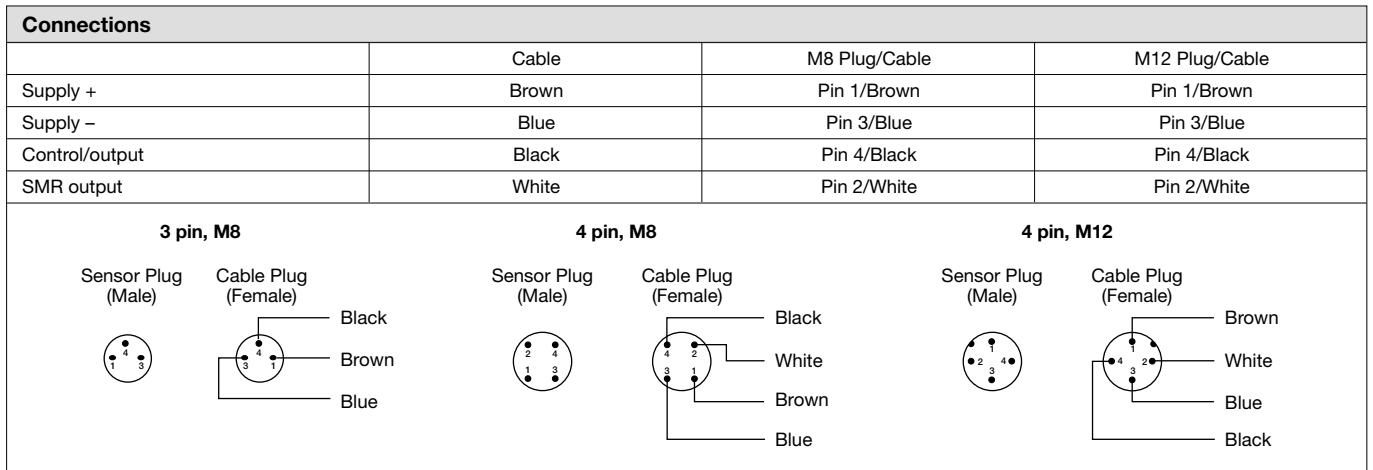

**Wiring Diagrams**

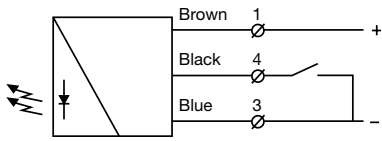

ON / OFF switch for transmitting power  
**SMT 6000**

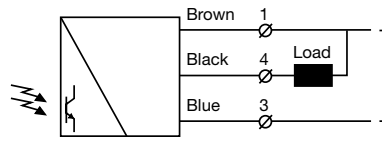

**SMR 6000 / 6100**

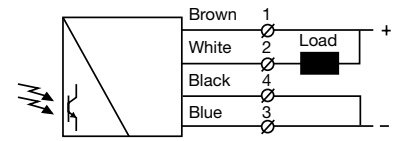

**SMR 6400 / 6500 (Load as NPN)**

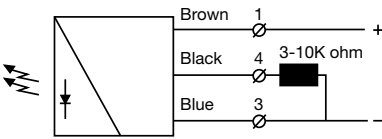

Variable Range  
**SMT 6000**

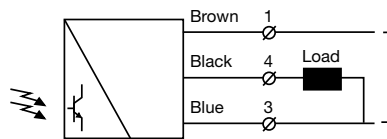

**SMR 6200 / 6300**

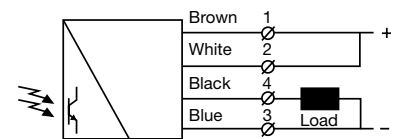

**SMR 6400 / 6500 (Load as PNP)**

**Dimensions**

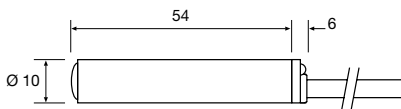

**AP/AS 5**

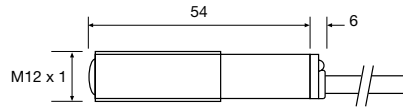

**TP/TS 5**

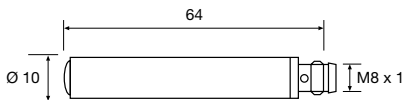

**AP/AS T3/T4**

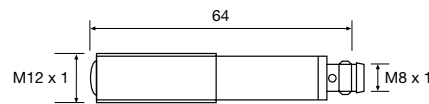

**TP/TS T3/T4**

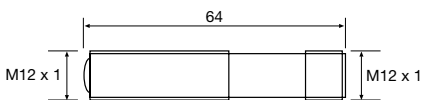

**TS J**

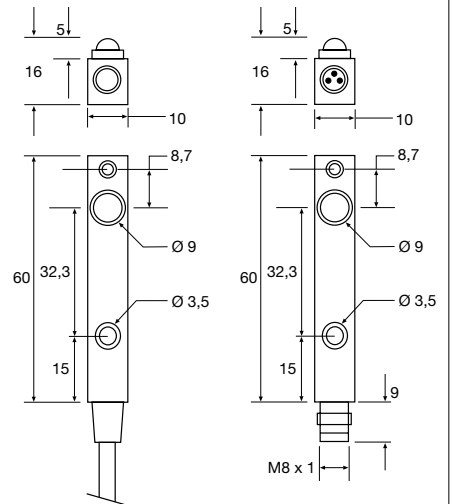

**SG 5**

**SG T3**

(Units in mm)

Telco reserves the right to change specifications without notice.

**Description**

- Operation mode and max sensing range:  
Thru beam: 0-25 m
- Cable or plug connection
- Sensitivity adjustment via potentiometer
- Switch selectable light or dark function
- Power and output indicators
- 10-30 V dc supply voltage
- 4 wire, NPN/PNP transistor or 4 wire, ambivalent PNP/PNP transistor output
- Control input



The 7000 series consists of a self-contained transmitter SMT, and a receiver SMR, which are to be used in thru beam mode. The receiver is offered with sensitivity adjustment via an integral potentiometer, and with either cable or plug connection.

The SMR is supplied with a 10-30 V dc supply voltage with either a 4 wire, NPN/PNP transistor with switch selectable light or dark function,

or 4 wire, ambivalent PNP/PNP output. The control input in the SMT may be used for either disabling or enabling the transmitting power temporarily for test purpose or for multiplexing applications.

Both the transmitter and receiver are protected against reverse polarity of power supplies, control input and output signals. The output is also protected against short circuit and inductive loads.

Technical Data		
	SMT	SMR
Supply voltage	10 – 30 V dc	
Voltage ripple	15 %	
Reverse polarity protected	Yes	
Short circuit protected	Yes	
Current consumption	20 mA	20 mA
Maximum output load	-	120 mA / 30 V dc
Maximum residual voltage	-	2 V
Maximum operation frequency	-	125 Hz
Response time $t_{ON} / t_{OFF}$	-	1/4 ms
Power on indicator	Green LED	-
Output indicator	-	Yellow LED
Hysteresis	-	15 – 20 %
Transmitter diode	Ga Al As (880 nm)	-
Opening angle	-	+/- 5°
Emission angle	+/- 4°	-

Environmental Data	
Vibration	10 – 55 Hz, 0,5 mm
Shock	30 g
Light immunity, @ 5° incidence	>20 000 lux
Temperature, operation	-20 to +50 °C
Temperature, storage	-40 to +80 °C
Sealing class	IP 67
Approvals	CE

Available Types										
	Type	Power Supply	Control Feature	Output	Connection		5 m Cable	4 pin, M8 Plug	4 pin, M12 Plug	Range
					Housing Material	Housing Size				
Transmitter	7000	10-30 V dc	Test input		Polycarbonate	M18 x 1	SMT 7000 TP 5	SMT 7000 TP T4	SMT 7000 TP J	0-25 metres
					Stainless Steel					

Receiver	7620	10-30 V dc	Sensitivity pot. and light/dark switch	NPN/PNP	Polycarbonate	M18 x 1	SMR 7620 TP 5	SMR 7620 TP T4	SMR 7620 TP J	25 metres
					Stainless Steel					
	7720		Sensitivity pot.	PNP/PNP	Polycarbonate		SMR 7720 TP 5	SMR 7720 TP T4	SMR 7720 TP J	
					Stainless Steel					

Connections			
	Cable	M8 Plug/Cable	M12 Plug/Cable
Supply +	Brown	Pin 1/Brown	Pin 1/Brown
Supply -	Blue	Pin 3/Blue	Pin 3/Blue
Control/output	Black	Pin 4/Black	Pin 4/Black
SMR output	White	Pin 2/White	Pin 2/White

  

**4 pin, M8**

**4 pin, M12**

Wiring Diagrams	
<p><b>SMT 7000</b></p>	<p><b>SMR 7620 (load as NPN)</b></p> <p>*Do not connect black wire</p>
<p><b>SMR 7720</b></p>	<p><b>SMR 7620 (load as PNP)</b></p> <p>*Do not connect white wire</p>

Dimensions

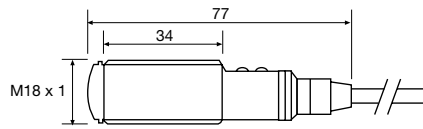

TP/TS 5

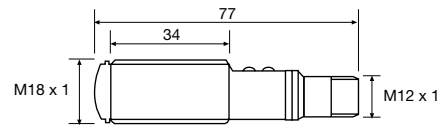

TP/TS J

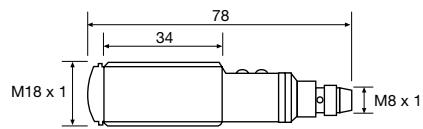

TP/TS T4

(Units in mm)

Telco reserves the right to change specifications without notice.



**Description**

- Operation mode and max sensing range:  
**Thru beam:** 0-20 m  
**Diffuse proximity:** 0-50 cm  
**Retro reflective:** 0-3 m  
**Fibre:** 0-75 cm
- Cable or plug connection
- Sensitivity adjustment via potentiometer
- Switch selectable light or dark function
- Power and output indicators
- High tolerance to hostile environments
- 10-30 V dc or 20-250 V ac supply voltage
- 3 wire, NPN or PNP transistor output or 2 wire, SCR output

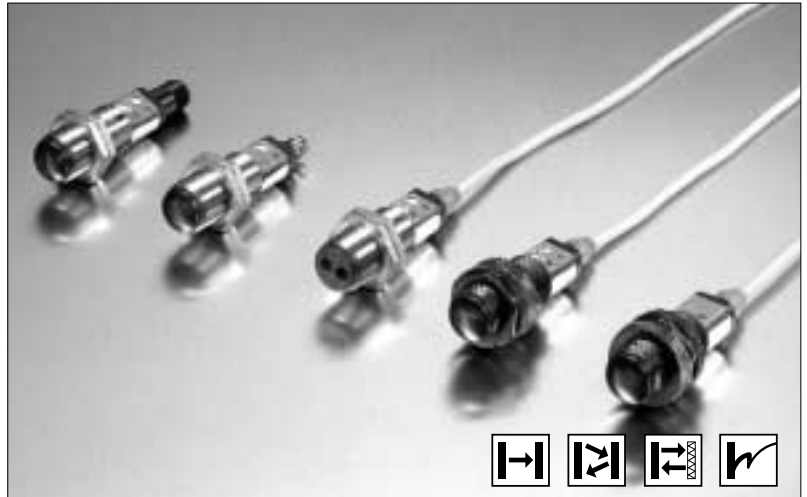

The 8000 series consists of a self-contained transmitter SMT, and a receiver SMR which are to be used in thru beam mode, an SMP for diffuse proximity, SMRR for retro reflective and an SMPF for use with fibre optic cables. All are offered with sensitivity adjustment via integral potentiometer with either cable or plug connection.

The complete series is available either as 3 wire, NPN or PNP transistor output with a 10-30 V dc supply voltage, or as 2 wire, SCR with a

20-250 V ac supply voltage both offering switch selectable light or dark function. The control input in the 10-30 V dc SMT is intended to be used for disabling or enabling the transmitting power temporarily for test purpose or for multiplexing applications.

The dc series is protected against reverse polarity of power supplies, control input and output signals. The output is protected against short circuit and inductive loads.

		Technical Data				
		SMT	SMR		SMP/SMPF	SMRR
			8x20	8x00		
Supply voltage	ac	20 – 250 V ac	–	20 – 250 V ac		
	dc	10 – 30 V dc				
Voltage ripple		15 %				
Reverse polarity protected	dc	Yes				
Short circuit protected	dc	–	Yes			
Current consumption	ac	3 mA	–	2 mA		
	dc	15 mA	5 mA		14 mA	
Maximum output load	ac	–	200 mA			
	dc	–	120 mA @ 30 V dc			
Maximum residual voltage	ac	–	8 V			
	dc	–	1,5 V			
Max. operation frequency	ac	–	25 Hz			
	dc	–	250 Hz			
Response time $t_{ON} / t_{OFF}$	ac	–	25 ms / 25 ms			
	dc	–	5 ms / 5 ms	2 ms / 2 ms		
Power on indicator		Green LED	–			
Output indicator		–	Yellow LED			
Hysteresis		–	Approx. 10 – 30 %		Approx. 3 – 10 %	
Transmitter diode		Ga Al As (880 nm)	–			
Opening angle		–	+/- 5°	+/- 4°	+/- 1,5°	
Emission angle		+/- 4°	–			

Environmental Data		
Vibration	10 – 55 Hz, 0,5 mm	
Shock	30 g	
Light immunity, @ 5° incidence	SMR 8 x 00 >10 000 lux, SMR 8 x 20 > 7000 lux	
Temperature, operation	-20 to +60 °C	
Temperature, storage	-40 to +80 °C	
Sealing class	ac	IP 60
	dc	IP 67
Approvals	ac	CE  cUL
	dc	CE

**Available Types**

Transmitter	Type	Power Supply	Control Feature	Output	Connection		5 m Cable	3 pin, M8 Plug	4 pin, M12 Plug	Range
					Housing Material	Housing Size				
					Order Reference					
8000	10 – 30 V dc	Test Input			Polycarbonate	M18 x 1	SMT 8000 PG 5	SMT 8000 PG T3	SMT 8000 PG J	20 metres
					Stainless Steel		SMT 8000 MG 5	SMT 8000 MG T3	SMT 8000 MG J	
8600	20 – 250 V ac	-			Polycarbonate	M18 x 1	SMT 8600 PG 5	-	-	7 metres
					Stainless Steel		SMT 8600 MG 5	-	-	

Receivers	Type	Power Supply	Control Feature	Output	Housing Material	Housing Size	5 m Cable	3 pin, M8 Plug	4 pin, M12 Plug	Range
8400	Stainless Steel	SMR 8500 MG 5	SMR 8500 MG T3	SMR 8500 MG J						
8520	10 – 30 V dc	Sensitivity pot. and light/dark switch	NPN	Polycarbonate	M18 x 1	SMR 8400 PG 5	SMR 8400 PG T3	SMR 8400 PG J	0-20 metres	
				Stainless Steel		SMR 8400 MG 5	SMR 8400 MG T3	SMR 8400 MG J		
8420	10 – 30 V dc	Sensitivity pot. and light/dark switch	PNP	Polycarbonate	M18 x 1	SMR 8520 PG 5	SMR 8520 PG T3	SMR 8520 PG J	0-20 metres	
				Stainless Steel		SMR 8520 MG 5	SMR 8520 MG T3	SMR 8520 MG J		
8800	20 – 250 V ac	Light/dark switch	NPN	Polycarbonate	M18 x 1	SMR 8420 PG 5	SMR 8420 PG T3	SMR 8420 PG J	7 metres	
				Stainless Steel		SMR 8420 MG 5	SMR 8420 MG T3	SMR 8420 MG J		
8800	20 – 250 V ac	Light/dark switch	SCR	Polycarbonate	M18 x 1	SMR 8800 PG 5	-	-	7 metres	
				Stainless Steel		SMR 8800 MG 5	-	-		

Proximity	Type	Power Supply	Control Feature	Output	Housing Material	Housing Size	5 m Cable	3 pin, M8 Plug	4 pin, M12 Plug	Range
8400	Stainless Steel	SMP 8500 MG 5	SMP 8500 MG T3	SMP 8500 MG J						
8800	20 – 250 V ac	Sensitivity pot. and light/dark switch	NPN	Polycarbonate	M18 x 1	SMP 8400 PG 5	SMP 8400 PG T3	SMP 8400 PG J	0-50 cm	
				Stainless Steel		SMP 8400 MG 5	SMP 8400 MG T3	SMP 8400 MG J		
8800	20 – 250 V ac	Sensitivity pot. and light/dark switch	SCR	Polycarbonate	M18 x 1	SMP 8800 PG 5	-	-	0-50 cm	
				Stainless Steel		SMP 8800 MG 5	-	-		

Fibre Sensors	Type	Power Supply	Control Feature	Output	Housing Material	Housing Size	5 m Cable	3 pin, M8 Plug	4 pin, M12 Plug	Range
8400	Stainless Steel	SMPF 8500 MG 5	SMPF 8500 MG T3	SMPF 8500 MG J						
8800	20 – 250 V ac	Sensitivity pot. and light/dark switch	NPN	Polycarbonate	M18 x 1	SMPF 8400 PG 5	SMPF 8400 PG T3	SMPF 8400 PG J	For ranges refer to page 43	
				Stainless Steel		SMPF 8400 MG 5	SMPF 8400 MG T3	SMPF 8400 MG J		
8800	20 – 250 V ac	Sensitivity pot. and light/dark switch	SCR	Polycarbonate	M18 x 1	SMPF 8800 PG 5	-	-	For ranges refer to page 43	
				Stainless Steel		SMPF 8800 MG 5	-	-		

Note: Fibre optic cables to be ordered separately.

Retro Reflective	Type	Power Supply	Control Feature	Output	Housing Material	Housing Size	5 m Cable	3 pin, M8 Plug	4 pin, M12 Plug	Range
8400	Stainless Steel	SMRR 8500 MG 5	SMRR 8500 MG T3	SMRR 8500 MG J						
8800	20 – 250 V ac	Sensitivity pot. and light/dark switch	NPN	Polycarbonate	M18 x 1	SMRR 8400 PG 5	SMRR 8400 PG T3	SMRR 8400 PG J	0-3 metres	
				Stainless Steel		SMRR 8400 MG 5	SMRR 8400 MG T3	SMRR 8400 MG J		
8800	20 – 250 V ac	Sensitivity pot. and light/dark switch	SCR	Polycarbonate	M18 x 1	SMRR 8800 PG 5	-	-	0-3 metres	
				Stainless Steel		SMRR 8800 MG 5	-	-		

Note: Reflectors to be ordered separately.

Connections

	Cable	M8 Plug/Cable	M12 Plug/Cable
AC supply	Blue & Brown	-	-
Supply +	Brown	Pin 1/Brown	Pin 1/Brown
Supply -	Blue	Pin 3/Blue	Pin 3/Blue
Control	Red	Pin 4/Black	Pin 4/Black
SMR output	Black	Pin 4/Black	Pin 3/Black

3 pin, M8

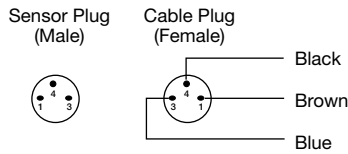

4 pin, M12

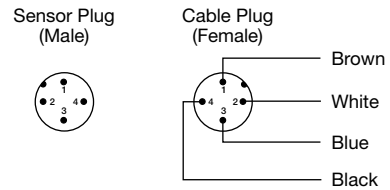

Wiring Diagrams

V ac Supply

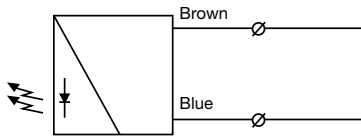

SMT 8600

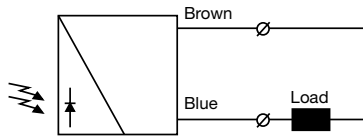

SMR 8800

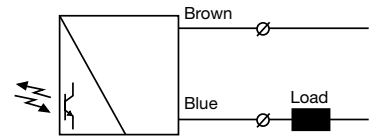

SMR / SMPF / SMRR 8800

V dc Supply

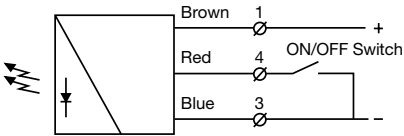

SMT 8000

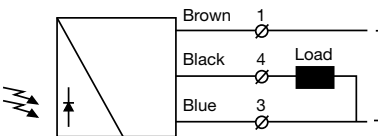

SMR 8500

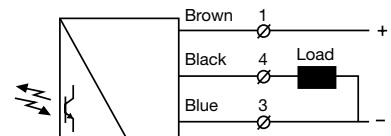

SMP / SMPF / SMRR 8500

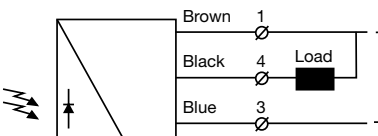

SMR 8400

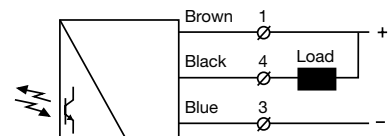

SMP / SMPF / SMRR 8400

**Dimensions**

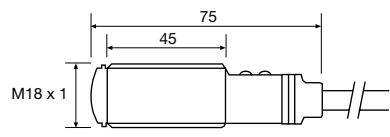

**AC PG/MG 5**

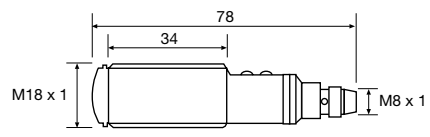

**DC PG/MG T3**

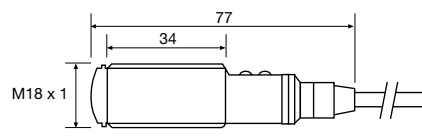

**DC PG/MG 5**

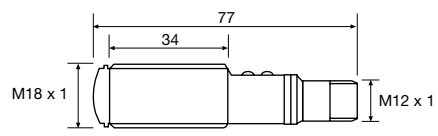

**DC PG/MG J**

(Units in mm)

Telco reserves the right to change specifications without notice.



**Description**

- 1 relay output
- 115 V ac or 230 V ac supply voltage
- Power and output indicators
- Adjustable on/off time delay
- Switch selectable light or dark function
- 11-pole DIN socket connection



The PP 00 is intended to be used in conjunction with a Spacemaster system, where there is a need for a relay output. This power pack series is supplied with a fixed 15 V dc output voltage, available with or without 0 – 10 on/off time delay second timer and a switch selectable light/dark function.

Technical Data	
Supply voltage	115 V ac, 230 V ac
Voltage tolerance	+/- 15%
Power consumption	Max. 4 VA
Relay output	1 open / 1 close 250 V ac / 3A, 120 V ac / 5A
Supply output voltage	15 V
Supply output current	175 mA
Power on indicator	Green LED
Input indicator	Green LED
Output indicator	Yellow LED
Housing material	Noryl

Environmental Data	
Temperature, operation	-10 to +50 °C
Temperature, storage	-40 to +80 °C
Sealing class	IP 40
Approvals	CE  

Available Types				
Model	Connection	Supply Voltage	115 V ac	230 V ac
		Output	Order Reference	
PP 00 A On/Off delay	11-pole DIN socket	Relay	PP 00 A 501	PP 00 A 500
PP 00 B			PP 00 B 501	PP 00 B 500

**Note:** Remote sensors and 11-pole DIN sockets to be ordered separately.

**Wiring Diagrams**

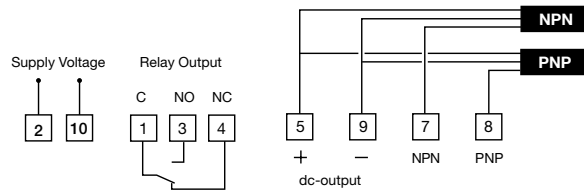

**Dimensions**

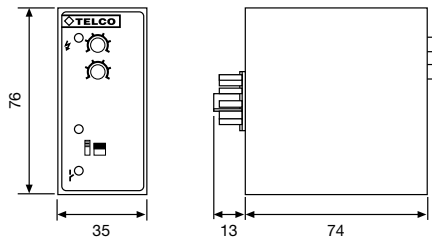

**PP 00 A**

(Units in mm)

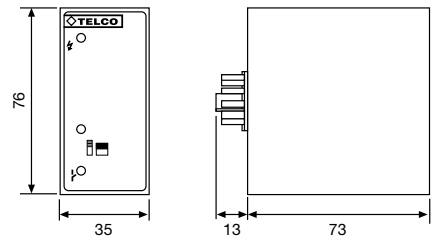

**PP 00 B**

(Units in mm)

Telco reserves the right to change specifications without notice.

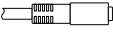
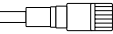
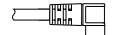
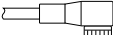

Cables								
Socket Type/Design		Locking Nut	Sealing Class	Material	Length	Connector		
						3 pin, M8	4 pin, M8	4 pin, M12
						Order reference		
Straight		No	IP 67	PVC	5m	<b>ELKA K 3308 PVC5M S</b>	<b>ELKA K 4408 PVC5M S</b>	—
		Yes				<b>ELKA KV 3308 PVC5M S</b>	<b>ELKA KV 4408 PVC5M S</b>	<b>ELKA KV 4412 PVC5M S</b>
Right Angle		No				<b>ELWIKA K 3308 PVC5M R</b>	<b>ELWIKA K 4408 PVC5M R</b>	—
		Yes				<b>ELWIKA KV 3308 PVC5M R</b>	<b>ELWIKA KV 4408 PVC5M R</b>	<b>ELWIKA KV 4412 PVC5M R</b>

**Note: For PUR CABLE replace 'PVC' in the order reference with 'PUR'. eg ELKA KV 4408 PUR5M R.**  
 Telco reserves the right to change specifications without notice.

## Fibre Optics

### Description

- Ideal for use in explosive areas
- Insensitive to electromagnetic and capacitive influence
- High temperature operation
- Various adaptor types
- Bifurcated or individual fibre construction

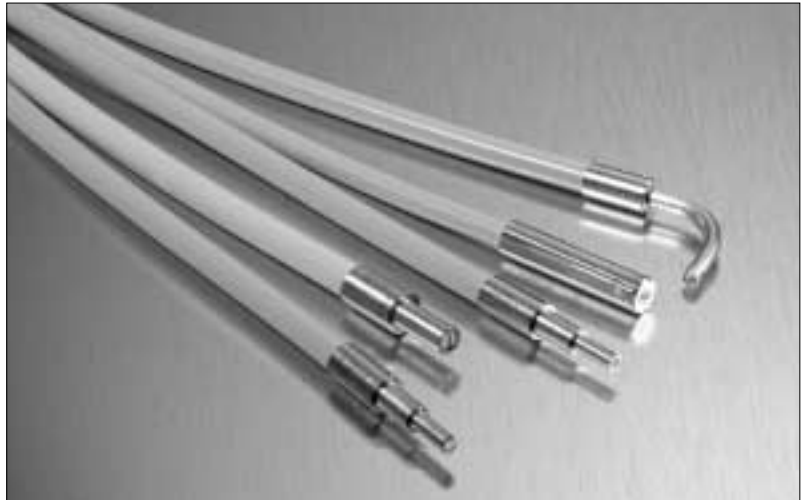

### Technical Data

Cover	Silicone
Sheath material	Stainless Steel
Sealing	IP 67
Strand diameter	50 $\mu$ m
Bundle diameter	1,0; 2,3; 3,5; 4,0; 4,5 mm
Opening angle	67 °
Adaptor Material	Stainless Steel (V2A)
Bending Radius	>5 x cover diameter
Temperature, Operation	-40 to +180 °C

Available types for Remote Photoelectric Systems						
Sensing End Tip Dimensions	Active Ø	Adaptor Type	Sensing Mode	Range	Cable Length	Order Reference
	4,0	A	Thru Beam	8 m	50 cm	<b>LLS 1306</b>
				6 m	1,5 m	<b>LLS 1326</b>
				7 m	1 m	<b>LLS 1308</b>
	4,5	B	Diffuse Proximity	70 cm	50 cm	<b>LYS 1309</b>
				60 cm	1 m	<b>LYS 1311</b>
	2,3	A	Thru Beam	2.5 m	1,5 m	<b>LLS 1316</b>
	0,3 x 20			1,4 m	60 cm	<b>LLS 1374</b>
				1,25 m	1 m	<b>LLS 1368</b>
Adaptor Type A – Individual Fibre Construction			Adaptor Type B – Bifurcated Fibre Construction			
(Units in mm)			(Units in mm)			

Note: Range specified using PA 11 in combination with remote sensor series 100.

# Fibre Optics

## Available types for SMPF 8000 Series

Sensing End Tip Dimensions	Active Ø	Adaptor Type	Sensing Mode	Range	Cable Length	Order Reference	
	1,0	C	Thru Beam	10 cm	60 cm	<b>LLS 1300</b>	
							<b>LYS 1301</b>
<b>Bendable Parts</b> 		D	Diffuse Proximity	4 mm			<b>LYS 1323</b>
	2,3	C	Thru Beam	60 cm			<b>LLS 1304</b>
		D	Diffuse Proximity	2,5 cm			<b>LYS 1305</b>
	2,3	C	Thru Beam	60 cm			<b>LLS 1302</b>
		D	Diffuse Proximity	2,5 cm			<b>LYS 1303</b>
	3,5	C	Thru Beam	75 cm			<b>LLS 1310</b>
		D	Diffuse Proximity	6 cm			<b>LYS 1307</b>
	1,0	C	Thru Beam	9 cm			<b>LLS 1312</b>
		D	Diffuse Proximity	3 mm			<b>LYS 1313</b>
	2,3	C	Thru Beam	55 cm			<b>LLS 1314</b>
		D	Diffuse Proximity	2,5 cm		<b>LYS 1315</b>	
	2,3	C	Thru Beam	45 cm		<b>LLS 1318</b>	
		D	Diffuse Proximity	2,5 cm		<b>LYS 1317</b>	
	0,3 x 20	C	Thru Beam	50 cm	20 cm	<b>LLS 1362</b>	
		D	Diffuse Proximity			<b>LYS 1371</b>	
		C	Thru Beam		1,5 m	<b>LLS 1370</b>	
Adaptor Type C – Individual Fibre Construction			Adaptor Type D – Bifurcated Fibre Construction				
(Units in mm)			(Units in mm)				

Telco reserves the right to change specifications without notice.



### Capacity Load:

A load which is only or partially capacitive. An example is PLC inputs. They are often noise protected by a capacitor. Another example is a long pair of wires, where the capacity between the wires is significant.

### Current Consumption:

The maximum current consumption for a unit when used at a specified voltage supply, or at the maximum rated voltage supply.

### Dark Function:

When referring to photoelectric systems, dark function means that the output will be active (a relay operates) when no light is received from the transmitter.

### Hysteresis:

An expression of the "inertness" of a system. For photoelectric systems the hysteresis is measured as a difference between the distance where sensors will see each other (L on) and the distance where they cannot see each other any more (L off). The hysteresis is normally expressed as a percentage of Lon.

### Inductive Load Protection:

Protection of a transistor output stage against voltage peaks occurring when an inductive load (relay, solenoid, coil) is switched off.

### Inverting of Relay Function:

When inverting, the function will be opposite i.e. if the relay was operated before, it will now be released.

### Life Time:

The lifetime is defined as the time a unit can operate until the performance decreases to a specified level. The lifetime will normally depend on operation conditions such as temperature and humidity.

### Light Function:

When referring to photoelectric systems, light function means that the output will be active (a relay operates) when light is received from the transmitter.

### NPN output:

An output where the load is connected to a common positive supply rail.

### Off delay:

The time delay between the absence (light mode operation) or presence (dark mode operation) of the IR beam and turning the output off.

### On delay:

The time delay between the presence (light mode operation) or absence (dark mode operation) of the IR beam and turning the output on.

### Output Short Circuit Protection:

Protection of a transistor output stage against damaging current flow, when the load is short circuited.

### Output Load:

Normally meant as a pure resistive load.

### PNP Output:

An output where the load is connected to a common negative supply rail.

### Residual Voltage:

When used in conjunction with outputs, it means the residual voltage over the output circuit, when it is active. The residual voltage will normally depend on the load current.

### Response Time:

The time delay between an event taking place and the registration being made. As an example, the time delay between a light beam in a photoelectric system is interrupted and the output relay has operated. It is often expressed in milliseconds (ms).

### Reverse Polarity Protection:

Protection against wrong (reverse) connection to the supply wires.

### Ripple:

Variation of the supply voltage with a frequency of 100 Hz (120 Hz). Expressed as a percentage of the actual supply voltage.

### Start Up Delay:

The time delay between power switched on and the unit functioning. During this time the function can either be undefined or defined, depending on the construction.

### Test input:

To test the function of the sensor, the transmitter can, for example, be switched off by a PLC in order to check whether the switching status changes at the relay or transistor output.

### Operation Modes:

 **Thru Beam:** In thru beam sensing mode, the transmitted light is transmitted directly to the receiver by the transmitter, which is mounted on the opposite side. Thru beam is the most effective use of infrared light, enabling the highest level of excess gain for reliable sensing through dust, dirt, fog or other harsh environments.

 **Diffuse Proximity:** In diffuse proximity sensing mode, both the transmitter and receiver are located on the same side, in separate or within the same housing. The transmitted light is reflected back to the receiver by the surface of the detected object itself. The sensing range is very dependent on the reflectivity of the detected object. Darker objects absorb more light than lighter and more shiny objects.

 **Retro Reflective:** In retro reflective sensing mode, both the transmitter and receiver are located on the same side, in separate or within the same housing. The transmitted light is reflected back to the receiver by means of a reflector mounted directly on the opposite side.

 **Fibre optic:** Individual fibre optic cables are used in pairs for thru beam sensing mode. Bifurcated fibre optic cables combine both the transmitted and received light in the same assembly, and are used for diffuse proximity. Most glass fibre optic cables are able to withstand corrosive materials and/or where the operation temperature is too high for the sensor electronics themselves.



## SpaceGuard – Light Curtain Systems

### Description

SG09

- 79 crossed beams
- 0-4 metre sensing range
- Automatic sensitivity adjustment
- 24 V dc power supply
- Solid-state relay output
- Automatic time out
- LED indication of system status
- 50 000 lux extraneous light immunity
- Slim line detector housing (10x28 mm)
- Detector length, 2,00 m or 2,10 m



### Description

SG11

- 16 to 64 parallel light beams
- 0-5 metre sensing range
- Automatic or manual sensitivity adjustment
- 230 V ac, 115 V ac, 24 V ac or 24 V dc supply voltage
- Relay or NPN output
- Selectable time out
- LED indication of system status
- 10 000 lux extraneous light immunity
- Alarm and time out output
- Slim line (10x28 mm) or leading edge (37,5x13 mm) detector housing
- Detector length, 57 cm up to 2,10 m

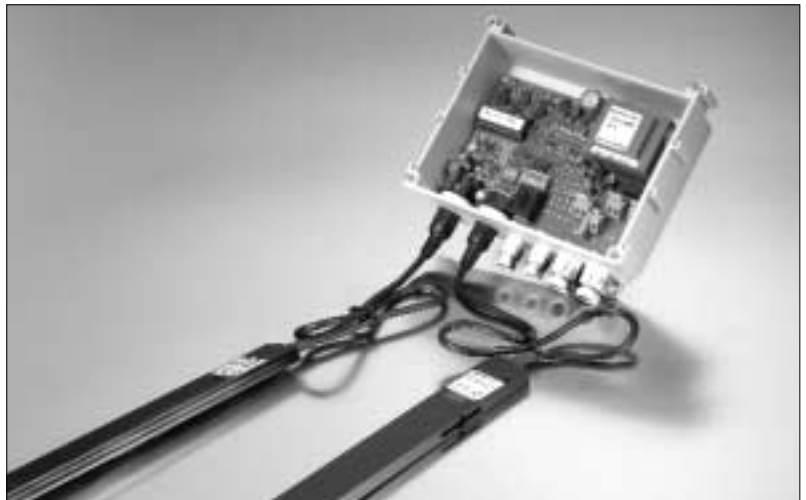

Telco can offer a complete range of light curtain systems.  
Please ask for your free SpaceGuard literature.

## Your local Telco Team

--

Telco's dealers named by Telco Teams, or Exclusive Importers, Business Partners or Distributors are not owned by Telco International Ltd. or any subsidiary of the holding companies behind Telco Production. Therefore, and as such, they have absolutely no authority to commit Telco International Ltd. or any subsidiary of the holding companies behind Telco Production to any pledge, contract or agreement, application in any form, by any means unless accepted beforehand by Telco International Ltd. or its subsidiaries.